

Grizzly **Industrial, Inc.**®

MODEL G0640X 17" WOOD/METAL BANDSAW OWNER'S MANUAL



COPYRIGHT © JANUARY, 2008 BY GRIZZLY INDUSTRIAL, INC.
**WARNING: NO PORTION OF THIS MANUAL MAY BE REPRODUCED IN ANY SHAPE
OR FORM WITHOUT THE WRITTEN APPROVAL OF GRIZZLY INDUSTRIAL, INC.**
#TR9556 PRINTED IN TAIWAN



WARNING!

This manual provides critical safety instructions on the proper setup, operation, maintenance and service of this machine/equipment.

Failure to read, understand and follow the instructions given in this manual may result in serious personal injury, including amputation, electrocution or death.

The owner of this machine/equipment is solely responsible for its safe use. This responsibility includes but is not limited to proper installation in a safe environment, personnel training and usage authorization, proper inspection and maintenance, manual availability and comprehension, application of safety devices, blade/cutter integrity, and the usage of personal protective equipment.

The manufacturer will not be held liable for injury or property damage from negligence, improper training, machine modifications or misuse.



WARNING!

Some dust created by power sanding, sawing, grinding, drilling, and other construction activities contains chemicals known to the State of California to cause cancer, birth defects or other reproductive harm. Some examples of these chemicals are:

- **Lead from lead-based paints.**
- **Crystalline silica from bricks, cement and other masonry products.**
- **Arsenic and chromium from chemically-treated lumber.**

Your risk from these exposures varies, depending on how often you do this type of work. To reduce your exposure to these chemicals: Work in a well ventilated area, and work with approved safety equipment, such as those dust masks that are specially designed to filter out microscopic particles.

Table of Contents

INTRODUCTION	2	SECTION 5: WOOD CUTTING	32
Foreword	2	Workpiece Inspection	32
Contact Info	2	Cutting Tips	32
Functional Overview	2	Ripping	33
Identification	3	Crosscutting	33
Machine Data Sheet	4	Resawing	34
SECTION 1: SAFETY	6	Stacked Cuts	35
Safety Instructions for Machinery	6	Cutting Curves	35
Additional Safety Instructions for Bandsaws ..	8	Cutting Circles	35
SECTION 2: CIRCUIT REQUIREMENTS	9	SECTION 6: METAL CUTTING	36
220V Operation	9	Workpiece Inspection	36
SECTION 3: SETUP	10	Cutting Tips	36
Setup Safety	10	Choosing Blades and Speeds	37
Items Needed for Setup	10	Metal Chip Inspection Chart	38
Unpacking	10	SECTION 7: ACCESSORIES	39
Inventory	11	SECTION 8: MAINTENANCE	41
Clean Up	12	Schedule	41
Site Considerations	12	Cleaning	41
Moving & Placing Bandsaw	13	Wheel Brush	41
Mounting	13	Lubrication	41
Assembly	14	Redressing Rubber Tires	43
Blade Tracking	17	SECTION 9: SERVICE	44
Test Run	18	Troubleshooting	44
Blade Tensioning	19	Replacing V-Belts	46
Adjusting Blade Guides	20	Adjusting Wheel Brush	46
Adjusting Support Bearings	21	Wheel Alignment	47
Adjusting Positive Stop	22	Shimming Table	49
Aligning Table	23	Blade Lead	49
Aligning Fence	24	Adjusting Tension Lever	50
Miter Gauge	24	Electrical Component Wiring	51
SECTION 4: OPERATIONS	25	Wiring Diagram	52
Operation Safety	25	Main Parts	53
Guide Post	25	Fence & Blade Guides	54
Quick Release Blade Tension	26	Parts List	55
Table Tilt	26	Labels	58
Blade Terminology	27	WARRANTY AND RETURNS	61
Blade Selection	27		
Blade Breakage	29		
Blade Care & Break-In	29		
Blade Changes	30		
Blade Speed	31		

INTRODUCTION

Foreword

We are proud to offer the Model G0640X 17" Wood/Metal Bandsaw. This machine is part of a growing Grizzly family of fine machinery. When used according to the guidelines set forth in this manual, you can expect years of trouble-free, enjoyable operation and proof of Grizzly's commitment to customer satisfaction.

The specifications, drawings, and photographs illustrated in this manual represent the Model G0640X as supplied when the manual was prepared. However, owing to Grizzly's policy of continuous improvement, changes may be made at any time with no obligation on the part of Grizzly.

For your convenience, we always keep current Grizzly manuals available on our website at www.grizzly.com. Any updates to your machine will be reflected in these manuals as soon as they are complete.

Contact Info

If you have any comments regarding this manual, please write to us at the address below:

Grizzly Industrial, Inc.
c/o Technical Documentation Manager
P.O. Box 2069
Bellingham, WA 98227-2069
Email: manuals@grizzly.com

We stand behind our machines. If you have any service questions or parts requests, please call or write us at the location listed below.

Grizzly Industrial, Inc.
1203 Lycoming Mall Circle
Muncy, PA 17756
Phone: (570) 546-9663
Fax: (800) 438-5901
E-Mail: techsupport@grizzly.com
Web Site: <http://www.grizzly.com>

Functional Overview

The bandsaw is one of the most versatile cutting tools in the shop and is capable of the following cuts:

- Mitters and angles
- Compound Angles
- Resaw Cuts
- Rip and Crosscuts
- Curves and Circles
- Stacked Cuts for Duplicate Parts

The blade is a flexible steel band with teeth on one edge that fits around two aligned wheels with slightly crowned rubber tires, which help the blade track in the center of the wheels during operation.

One wheel stays in a fixed position and is driven by a motor. The other wheel spins freely and adjusts toward or away from the fixed wheel, which controls the tension of the installed blade. This wheel usually also features a tracking control that tilts the wheel forward or backward to ensure the blade rides in the center of the wheel. The rotation of both wheels pulls the blade downward toward the table.

When a workpiece is pushed against the moving blade, the downward force of the blade teeth scrape across the workpiece and, in effect, cut it. Blade guides on both sides of the cutting area keep the blade from flexing or being pushed off the wheels from the horizontal pressure of the workpiece while cutting.

Since the purpose of the blade guides is to provide support while cutting, they should be as close as possible to the blade; however, the blade guides should only touch the blade while a workpiece is being cut, or the constant friction will reduce the life of the blade. Also the upper blade guide assembly should be adjusted as close as possible to the workpiece to provide maximum support and cover any unused area of the blade with the blade guard.



Identification

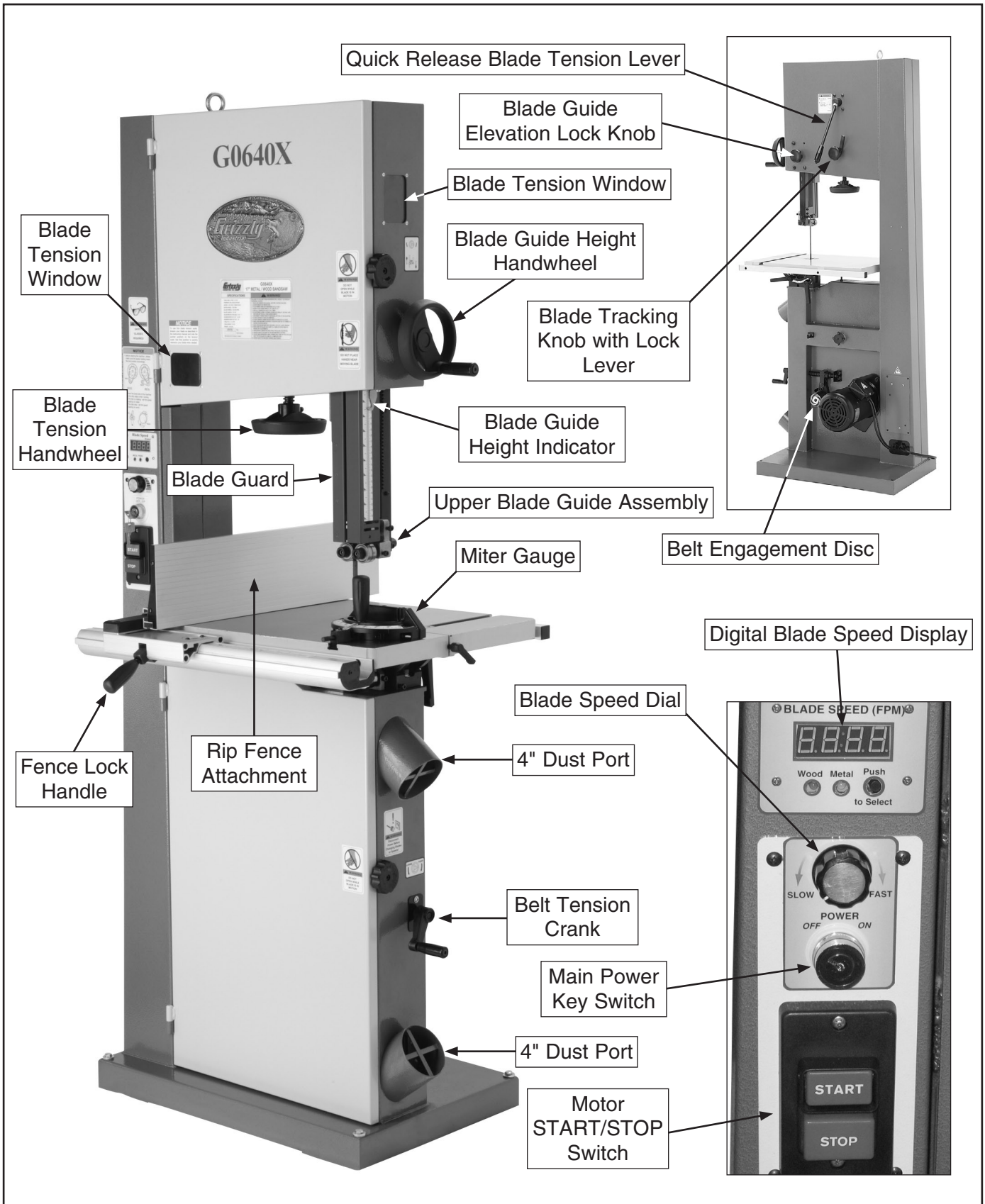



MACHINE DATA SHEET

Customer Service #: (570) 546-9663 • To Order Call: (800) 523-4777 • Fax #: (800) 438-5901

MODEL G0640X 17" WOOD/METAL CUTTING BANDSAW

Product Dimensions:

Weight 378 lbs.
Length/Width/Height 32" x 32" x 73"
Footprint (Length/Width) 27" x 17³/₄"

Shipping Dimensions:

Type Wood Slat Crate
Content Machine
Weight 433 lbs.
Length/Width/Height 31" x 20" x 81"

Electrical:

Required Power Source 220V, Single-Phase
Switch ON/OFF Push Button with Locking Key Switch
Cord Length 6 ft.
Cord Gauge 14 gauge
Recommended Circuit Size 15 amp
Plug Included No
Recommended Plug 6-15

Motor:

Horsepower 2 HP
Voltage 220V
Phase 3-Phase
Cycle 60 Hz
Type Induction
Amps 8A
Speed 1725 RPM
Motor Bearings Shielded and Lubricated
Power Transfer Belt Drive
Coolant Fan 16 Watt; 0.13A

Main Specifications:

Throat Capacity Left-of-Blade 16¹/₄"
Maximum Resaw Height 12"
Blade Speeds Variable 100-3600 FPM
Blade Length 131¹/₂"
Blade Width Range 1/8"-1"
Table Size (Length, Width, Thickness) 23⁵/₈" x 17¹/₄" x 1¹/₂"
Table Tilt -5° to 45°
Table Height from Floor 37¹/₂"
Wheel Diameter 17"
Number of Dust Ports 2
Dust Port Size 4"
Fence Locking Location Front



Construction Materials:

Wheels Fully Balanced Cast Iron
Wheel Bearings..... Sealed and Lubricated
Wheel Covers Steel
Table Precision Ground Cast Iron
Fence Precision Ground Cast Iron
Resaw Fence Deluxe Extruded Aluminum
Base Steel
Body Steel
Paint Powder Coated

Other Specifications:

Compatible Shop Fox Mobile Base Available from Grizzly G7315
Country Of Origin Taiwan
Sound Rating 78 dB
Warranty 1 Year
Serial Number Location ID Label on Center of Upper Wheel Cover
Approximate Assembly & Setup Time 1 Hour



SECTION 1: SAFETY

WARNING

For Your Own Safety, Read Instruction Manual Before Operating this Machine

The purpose of safety symbols is to attract your attention to possible hazardous conditions. This manual uses a series of symbols and signal words intended to convey the level of importance of the safety messages. The progression of symbols is described below. Remember that safety messages by themselves do not eliminate danger and are not a substitute for proper accident prevention measures.

 **DANGER** Indicates an imminently hazardous situation which, if not avoided, **WILL** result in death or serious injury.

 **WARNING** Indicates a potentially hazardous situation which, if not avoided, **COULD** result in death or serious injury.

 **CAUTION** Indicates a potentially hazardous situation which, if not avoided, **MAY** result in minor or moderate injury. It may also be used to alert against unsafe practices.

NOTICE This symbol is used to alert the user to useful information about proper operation of the machine.

WARNING

Safety Instructions for Machinery

- 1. READ THE ENTIRE MANUAL BEFORE STARTING MACHINERY.** Machinery presents serious injury hazards to untrained users.
- 2. ALWAYS USE ANSI APPROVED SAFETY GLASSES WHEN OPERATING MACHINERY.** Everyday eyeglasses only have impact resistant lenses—they are NOT safety glasses.
- 3. ALWAYS WEAR A NIOSH APPROVED RESPIRATOR WHEN OPERATING MACHINERY THAT PRODUCES DUST.** Most types of dust (wood, metal, etc.) can cause severe respiratory illnesses.
- 4. ALWAYS USE HEARING PROTECTION WHEN OPERATING MACHINERY.** Machinery noise can cause permanent hearing loss.
- 5. WEAR PROPER APPAREL. DO NOT** wear loose clothing, gloves, neckties, rings, or jewelry that can catch in moving parts. Wear protective hair covering to contain long hair and wear non-slip footwear.
- 6. NEVER OPERATE MACHINERY WHEN TIRED OR UNDER THE INFLUENCE OF DRUGS OR ALCOHOL.** Be mentally alert at all times when running machinery.



WARNING

Safety Instructions for Machinery

7. **ONLY ALLOW TRAINED AND PROPERLY SUPERVISED PERSONNEL TO OPERATE MACHINERY.** Make sure operation instructions are safe and clearly understood.
8. **KEEP CHILDREN AND VISITORS AWAY.** Keep all children and visitors a safe distance from the work area.
9. **MAKE WORKSHOP CHILDPROOF.** Use padlocks, master switches, and remove start switch keys.
10. **NEVER LEAVE WHEN MACHINE IS RUNNING.** Turn power **OFF** and allow all moving parts to come to a complete stop before leaving machine unattended.
11. **DO NOT USE IN DANGEROUS ENVIRONMENTS.** DO NOT use machinery in damp, wet locations, or where any flammable or noxious fumes may exist.
12. **KEEP WORK AREA CLEAN AND WELL LIGHTED.** Clutter and dark shadows may cause accidents.
13. **USE A GROUNDED EXTENSION CORD RATED FOR THE MACHINE AMPERAGE.** Grounded cords minimize shock hazards. Undersized cords create excessive heat. Always replace damaged extension cords.
14. **ALWAYS DISCONNECT FROM POWER SOURCE BEFORE SERVICING MACHINERY.** Make sure switch is in OFF position before reconnecting.
15. **MAINTAIN MACHINERY WITH CARE.** Keep blades sharp and clean for best and safest performance. Follow instructions for lubricating and changing accessories.
16. **MAKE SURE GUARDS ARE IN PLACE AND WORK CORRECTLY BEFORE USING MACHINERY.**
17. **REMOVE ADJUSTING KEYS AND WRENCHES.** Make a habit of checking for keys and adjusting wrenches before turning machinery **ON**.
18. **CHECK FOR DAMAGED PARTS BEFORE USING MACHINERY.** Check for binding or misaligned parts, broken parts, loose bolts, and any other conditions that may impair machine operation. Repair or replace damaged parts before operation.
19. **USE RECOMMENDED ACCESSORIES.** Refer to the instruction manual for recommended accessories. Improper accessories increase risk of injury.
20. **DO NOT FORCE MACHINERY.** Work at the speed for which the machine or accessory was designed.
21. **SECURE WORKPIECE.** Use clamps or a vise to hold the workpiece when practical. A secured workpiece protects your hands and frees both hands to operate the machine.
22. **DO NOT OVERREACH.** Maintain stability and balance at all times.
23. **MANY MACHINES CAN EJECT WORKPIECES TOWARD OPERATOR.** Know and avoid conditions that cause the workpiece to "kickback."
24. **ALWAYS LOCK MOBILE BASES (IF USED) BEFORE OPERATING MACHINERY.**
25. **CERTAIN DUST MAY BE HAZARDOUS** to the respiratory systems of people and animals, especially fine dust. Be aware of the type of dust you are exposed to and always wear a respirator designed to filter that type of dust.



WARNING

Additional Safety Instructions for Bandsaws

- 1. BLADE CONDITION.** Do not operate with a dull, cracked, or badly worn blade. Dull blades require more effort to use and are difficult to control. Inspect blades for cracks and missing teeth before each use.
- 2. HAND PLACEMENT.** Never position hands in line with the cut. Serious personal injury could occur.
- 3. GUARDS.** Do not operate this bandsaw without the blade guard in place or with the doors open.
- 4. BLADE REPLACEMENT.** When replacing blades, make sure teeth face down toward the table and the blade is properly tensioned before operating.
- 5. WORKPIECE HANDLING.** Never hold small workpieces with your fingers during a cut. Always support/feed the workpiece with push stick, table support, vise, or some type of clamping fixture.
- 6. CUTTING TECHNIQUES.** Plan your cuts so you always cut out of the wood. DO NOT back the workpiece away from the blade while the saw is running. If you need to back the work out, turn the bandsaw **OFF** and wait for the blade to come to a complete stop, and DO NOT twist or put excessive stress on the blade while backing work away.
- 7. LEAVING WORK AREA.** Never leave the machine running and unattended. Allow the bandsaw to come to a complete stop before you leave it unattended.
- 8. FEED RATE.** Always feed stock evenly and smoothly. DO NOT force or twist blade while cutting, especially when sawing small curves.
- 9. BLADE SPEED.** Allow blade to reach full speed before cutting.
- 10. MAINTENANCE/SERVICE.** All inspections, adjustments, and maintenance are to be done with the power **OFF** and the plug removed from the outlet. Wait for all moving parts to come to a complete stop.
- 11. BLADE CONTROL.** Do not attempt to stop or slow the blade with your hand or a workpiece. Allow the blade to stop on its own, unless your machine is equipped with a brake.
- 12. UNSTABLE WORKPIECES.** Workpieces that cannot be supported or stabilized without a vise should not be cut on a vertical metal-cutting bandsaw, because they can unexpectedly move while cutting and entangle the operator's hands into the blade. Examples are chains, cables, round or oblong-shaped workpieces, workpieces with internal or built-in moving or rotating parts, etc.
- 13. DUST COLLECTION.** Mixing metal cuttings with wood dust greatly increases the risk of fire. Wood dust collectors are not designed to collect metal. Instead use a wet/dry vacuum or Shop•Vac to collect metal cuttings from the bandsaw.
- 14. WOOD/METAL CONVERSION.** Wood dust on or in the bandsaw may catch fire if exposed to hot metal cuttings. To reduce this risk, thoroughly vacuum any wood dust from inside and outside the bandsaw when converting bandsaw for metal cutting.
- 15. EXPERIENCING DIFFICULTIES.** If at any time you are experiencing difficulties performing the intended operation, stop using the machine! Contact our Technical Support Department at (570) 546-9663.



SECTION 2: CIRCUIT REQUIREMENTS

220V Operation

⚠️ WARNING

Serious personal injury could occur if you connect the machine to power before completing the setup process. **DO NOT** connect the machine to the power until instructed later in this manual.



⚠️ WARNING

Electrocution or fire could result if machine is not grounded and installed in compliance with electrical codes. Compliance **MUST** be verified by a qualified electrician!

Full Load Amperage Draw

This machine draws the following amps under maximum load:

Amp Draw..... 8 Amps

Power Supply Circuit Requirements

You **MUST** connect your machine to a grounded circuit that is rated for the amperage given below. Never replace a circuit breaker on an existing circuit with one of higher amperage without consulting a qualified electrician to ensure compliance with wiring codes. **If you are unsure about the wiring codes in your area or you plan to connect your machine to a shared circuit, consult a qualified electrician.**

Minimum Circuit Size..... 15 Amps

Power Connection Device

The type of plug required to connect your machine to power depends on the type of service you currently have or plan to install. We recommend using the plug shown in **Figure 1**.

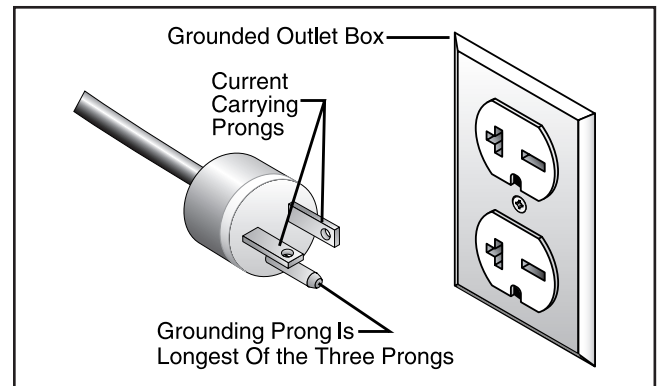

Figure 1. NEMA 6-15 plug and receptacle.

Extension Cords

Using extension cords may reduce the life of the motor. Instead, place the machine near a power source. If you must use an extension cord:

- Use at least a 14 gauge cord that does not exceed 50 feet in length!
- The extension cord must also have a ground wire and plug pin.
- A qualified electrician **MUST** size cords over 50 feet long to prevent motor damage.



SECTION 3: SETUP

Setup Safety

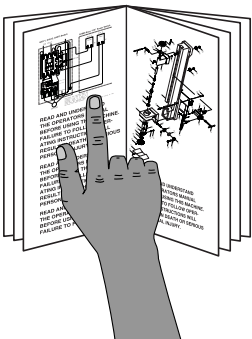

⚠️ WARNING
This machine presents serious injury hazards to untrained users. Read through this entire manual to become familiar with the controls and operations before starting the machine!



⚠️ WARNING
Wear safety glasses during the entire set up process!

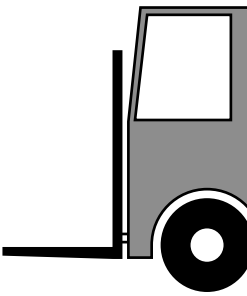

⚠️ WARNING
This is an extremely heavy machine. Serious personal injury may occur if safe moving methods are not followed. To be safe, you will need assistance and a forklift or pallet jack when moving the shipping crate.



⚠️ WARNING
Some inventory components are very heavy. DO NOT over-exert yourself while unpacking, moving, or installing them—get assistance.

Items Needed for Setup

The following items are needed to complete the setup process, but are not included with your machine:

Description	Qty
• Straightedge	1
• Level	1
• Another Person for Lifting Help	1
• Forklift.....	1
• Lifting Strap or Chain (500 lb min. cap.)	1
• Lifting Hook or Shackle	1
• Square.....	1
• Feeler Gauge 0.016"	1
• Safety Glasses (for each person)	1
• Wet/Dry Vacuum for Dust Collection	1
• Vacuum Adaptor 4"	1
• Dust Hose Y-Fitting 4".....	1
• Dust Hose 4" (length as needed).....	2
• Hose Clamp 4"	4

Unpacking

The Model G0640X was carefully packed when it left our warehouse. If you discover the machine is damaged after you have signed for delivery, *please immediately call Customer Service at (570) 546-9663 for advice.*

Save the containers and all packing materials for possible inspection by the carrier or its agent. *Otherwise, filing a freight claim can be difficult.*

When you are completely satisfied with the condition of your shipment, you should inventory the contents.



Inventory

After all parts have been removed from the three boxes, you should have the following items:

Main Components: (Figure 2 & 3)		Qty
A.	Bandsaw (not shown).....	1
B.	Table	1
C.	Miter Gauge.....	1
D.	Fence Assembly.....	1
E.	Resaw Fence Attachment	1
F.	Front Fence Rail.....	1
G.	Rear Fence Rail	1
H.	Handwheel (not shown)	1
I.	V-Belt A27 (not shown)	1
J.	Scale (not shown)	1

Fasteners (and where used):		Qty
	Hex Bolt M8-1.25 x 100 (Positive Stop).....	1
	Hex Nut M8-1.25 (Positive Stop).....	1
	Cap Screw M6-1 x 20 (Handwheel)	1
	Hex Bolts M8-1.25 x 16 (Table)	4
	Lock Washers 8mm (Table)	4
	Flat Washers 8mm (Table).....	4
	Cap Screws M6-1 x 25 (Rear Rail)	2
	Hex Bolts M6-1 x 20 (Front Rail).....	2
	Lock Washers 6mm (Front Rail)	2
	Flat Washers 6mm (Front Rail)	2
	Hex Nut M8-1.25 (Fence Lock Lever).....	1
	Hex Nut M6-1 (Rail Pad).....	1
	Flat Washer 8mm (Attachment Lock Handle) ...	1

Tools & Other Miscellaneous Items:		Qty
	Hex Wrench 5mm.....	1
	Hex Wrench 8mm.....	1
	Open End Wrench 10/13mm.....	1
	Table Pin	1
	Table Insert	1
	Rail Pad M6-1 x 18 (attaches to fence)	1
	Fence Lock Lever M8-1.25 x 22	1
	Fence Attachment Lock Handle M8-1.25 x 44..	1
	Fence Attachment T-Slot Nut.....	1

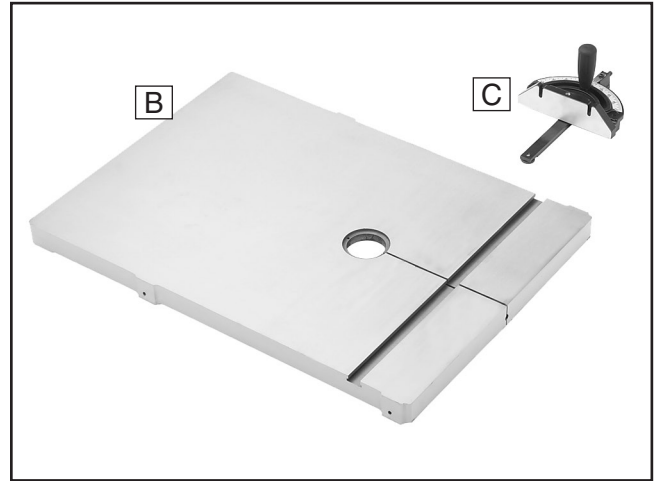

Figure 2. Bandsaw components.

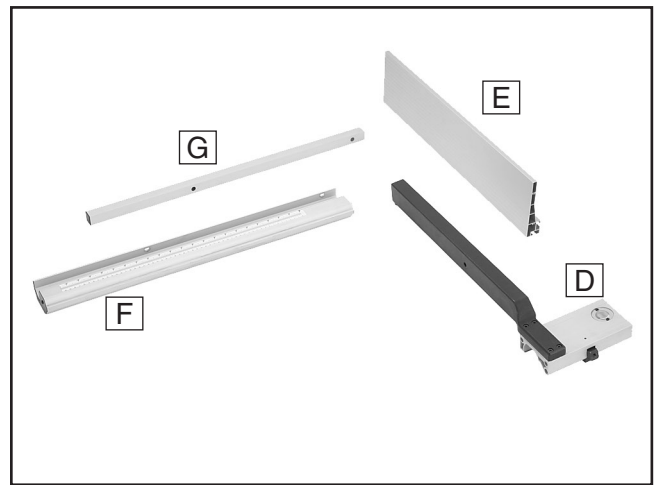

Figure 3. Fence components.

If any nonproprietary parts are missing (e.g. a nut or a washer), we will gladly replace them, or for the sake of expediency, replacements can be obtained at your local hardware store.

NOTICE

Some hardware/fasteners on the inventory list may arrive pre-installed on the machine. Check these locations before assuming that any items from the inventory list are missing.



Clean Up

The unpainted surfaces are coated with a waxy oil to prevent corrosion during shipment. Remove this protective coating with a solvent cleaner or degreaser shown in **Figure 4**. For thorough cleaning, some parts must be removed. **For optimum performance from your machine, clean all moving parts or sliding contact surfaces.** Avoid chlorine-based solvents, such as acetone or brake parts cleaner that may damage painted surfaces. Always follow the manufacturer's instructions when using any type of cleaning product.

	<p>! WARNING Gasoline and petroleum products have low flash points and can explode or cause fire if used to clean machinery. DO NOT use these products to clean the machinery.</p>
---	--

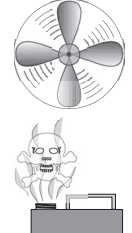
	<p>! CAUTION Many cleaning solvents are toxic if inhaled. Minimize your risk by only using these products in a well ventilated area.</p>
---	---

G2544—Solvent Cleaner & Degreaser
A great product for removing the waxy shipping grease from your machine during clean up.

<p>Call 1-800-523-4777 To Order</p>	
--	---

Figure 4. Cleaner/degreaser available from Grizzly.

Site Considerations

Floor Load

Refer to the **Machine Data Sheet** for the weight and footprint specifications of your machine. Some residential floors may require additional reinforcement to support both the machine and operator.

Placement Location

Consider existing and anticipated needs, size of material to be processed through each machine, and space for auxiliary stands, work tables or other machinery when establishing a location for your new machine. See **Figure 5** for the minimum working clearances.

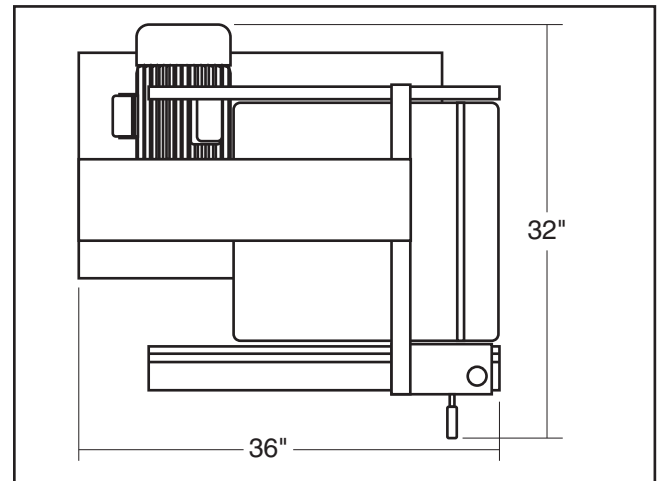

Figure 5. Minimum working clearances.

	<p>! CAUTION Children and visitors may be seriously injured if unsupervised. Lock all entrances to the shop when you are away. DO NOT allow unsupervised children or visitors in your shop at any time!</p>
--	---



Moving & Placing Bandsaw

⚠️ WARNING

This is an extremely heavy machine. Serious personal injury may occur if safe moving methods are not followed. To be safe, you will need assistance and a forklift or a hoist when removing the machine from the crate. Use a chain or a lifting strap with a minimum of 500 lbs. lifting capacity. If the chain or lifting strap breaks, serious personal injury may occur.

Special care should be taken when moving this bandsaw. Only use the following methods to lift or move this bandsaw.

To move and place the bandsaw:

1. Use a forklift to move the bandsaw on the pallet near its final location.
2. Unbolt the bandsaw from the pallet.
3. Place the lifting hook through the eye bolt (**Figure 6**) that is located on top of the machine.
4. Carefully lift the machine and place where desired.

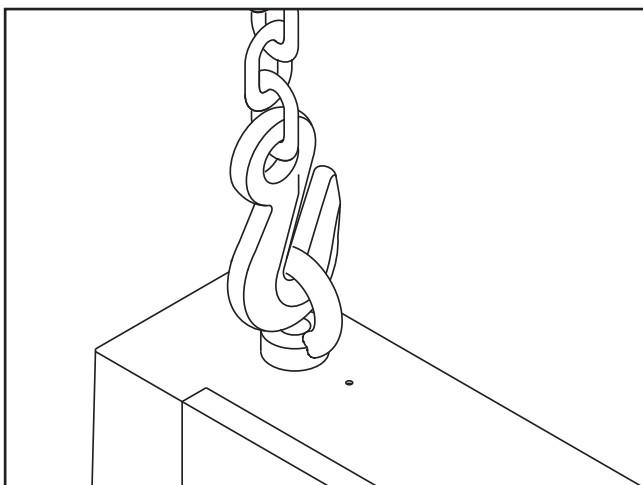

Figure 6. Lifting the bandsaw.

Mounting

We recommend mounting your new machine to the floor. Because floor materials may vary, floor mounting hardware is not included. You may also mount your machine to a mobile base (such as shown in **Figure 7**) with wheel locking or wheel retracting capabilities that prevent rolling when not in use.



Figure 7. Model G7315 Shop Fox mobile base.

Bolting to Concrete Floors

Lag shield anchors with lag bolts (**Figure 8**) and anchor studs are two popular methods for anchoring an object to a concrete floor. We suggest you research the many options and methods for mounting your machine and choose the best that fits your specific application.

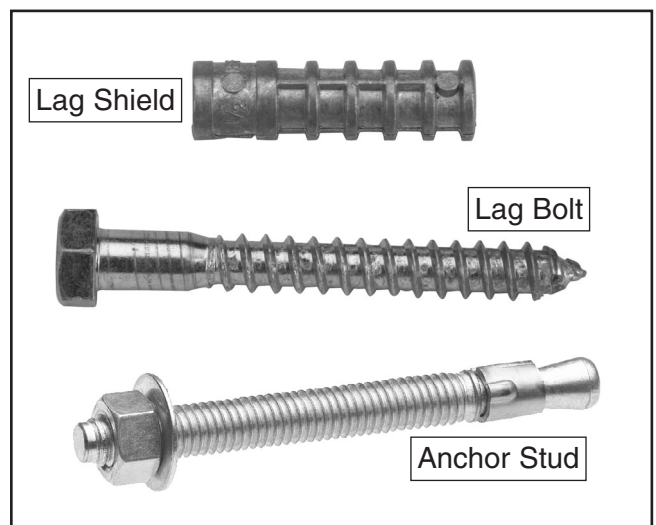

Figure 8. Typical concrete mounting fasteners.



Assembly

To assemble the bandsaw:

1. Thread an M8-1.25 hex nut half way up the length of the included M8-1.25 x 100 hex bolt (the longest one in the hardware bag).
2. Thread the M8-1.25 x 100 hex bolt (otherwise known as the "Positive Stop Bolt") into the casting near the trunnion base, as shown in **Figure 9**.

Note: The positive stop bolt acts as a table stop, which makes it easy to bring the table back to 90° after tilting it.

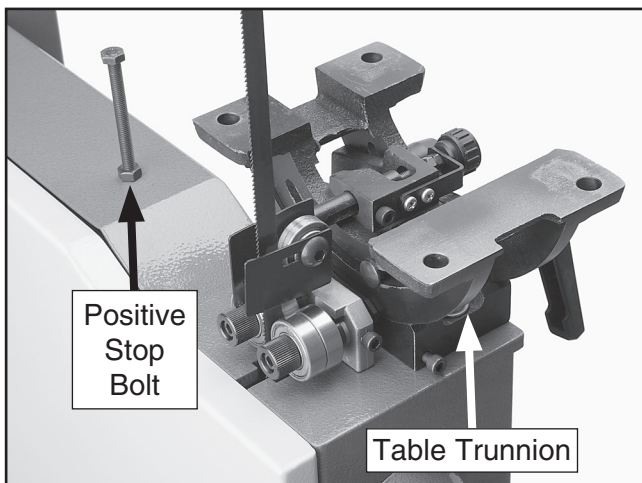

Figure 9. Positive stop bolt installed.

3. Slide the handwheel onto the shaft, as shown in **Figure 10**, and thread the M6-1 x 20 cap screw through the side of the handwheel and against the shaft to secure the handwheel in place.



Figure 10. Handwheel installed.

4. Loosen blade tension by rotating the quick release tension lever clockwise as shown in **Figure 11**.

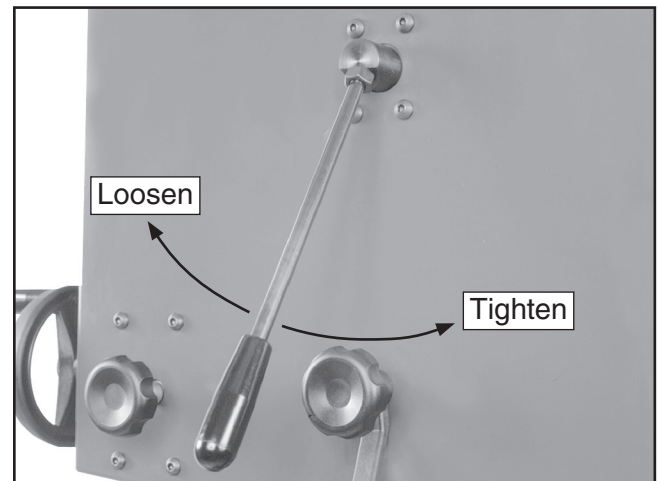
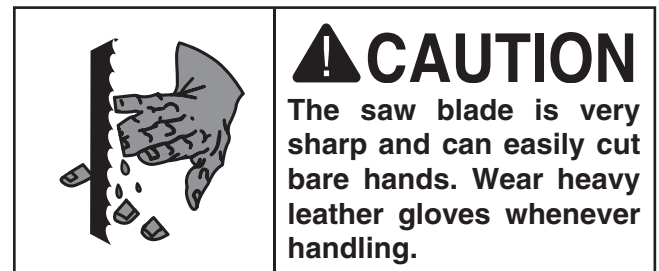
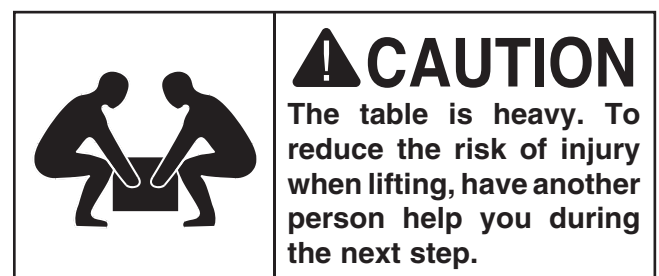

Figure 11. Quick release tension lever.

5. Adjust the upper and lower blade guides away from the blade. Refer to **Adjusting Blade Guides** on **Page 20** for more details.



6. Open the upper and lower wheel covers, and slide the blade off of both wheels.



7. Place the table onto the trunnion and position it so the mounting holes in the table are aligned with those on the trunnion.



8. Attach the table to the trunnion with four M8-1.25 x 16 hex bolts, 8mm lock washers, and 8mm flat washers.
9. With the blade teeth pointing downward, slide the blade through the table slot.
10. Slide the blade through the upper and lower blade guides, and mount it over the upper and lower wheels.
11. Tighten the quick release tension lever, then install the table insert and table pin.

Note: Keep the upper and lower blade guides adjusted away from the blade until the blade tracking and tension have been adjusting during later steps.

12. Adjust the blade tension until the mark on the blade tension scale is between 4 and 6.
13. Attach the rear rail to the table with the two M6-1 x 25 cap screws (see **Figure 12**).

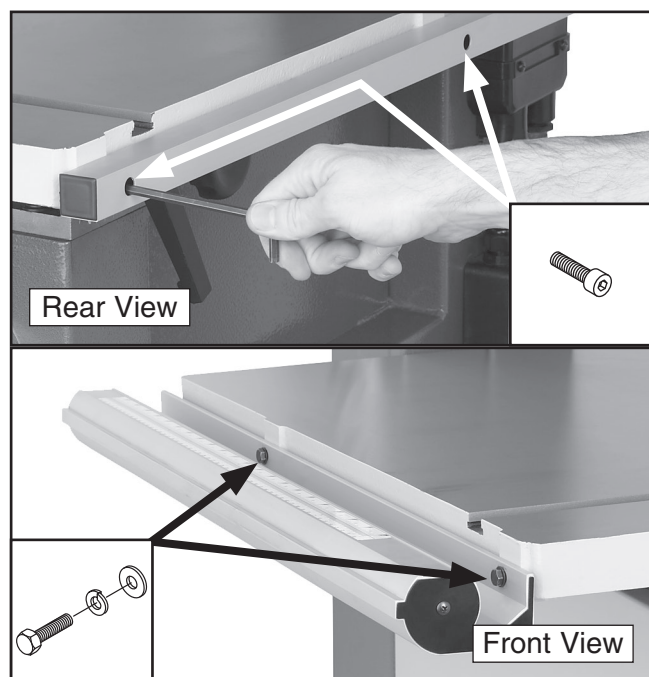

Figure 12. Rail installation.

14. Attach the front rail with the M6-1 x 20 hex bolts, lock washers, and flat washers as shown in **Figure 12**.

15. Install an M8-1.25 hex nut on the fence lock lever, then thread the handle into the fence assembly (**Figure 13**). Tighten the hex nut against the fence pivot block to secure the handle.

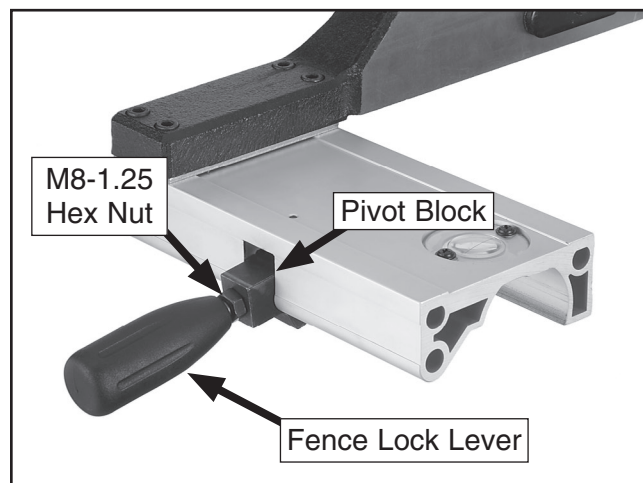

Figure 13. Handle installed on fence assembly.

16. Thread the M6-1 hex nut onto the rail pad, then thread the rail pad into the underside of the back end of the fence (see **Figure 14**).

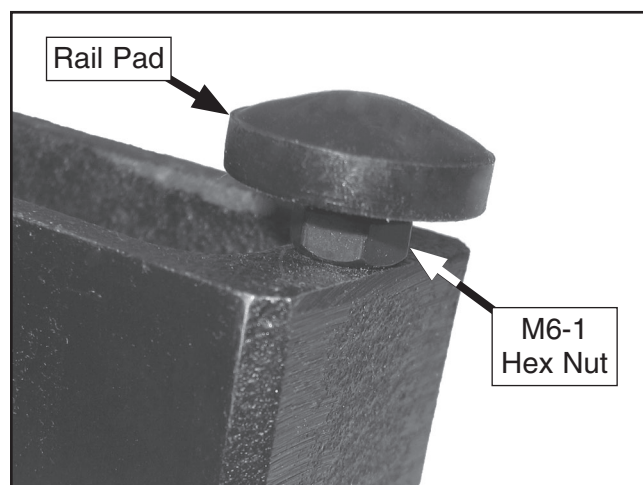

Figure 14. Installed rail pad on back end of fence.

17. Place the 8mm flat washer on the fence attachment lock handle, slide it through the hole in the fence, then thread the T-slot nut onto the end of the lock handle threads.



- Slide the resaw fence over the T-slot nut, as shown in **Figure 15**, so the T-slot nut fits inside the channel of the resaw fence, then tighten the lock handle.

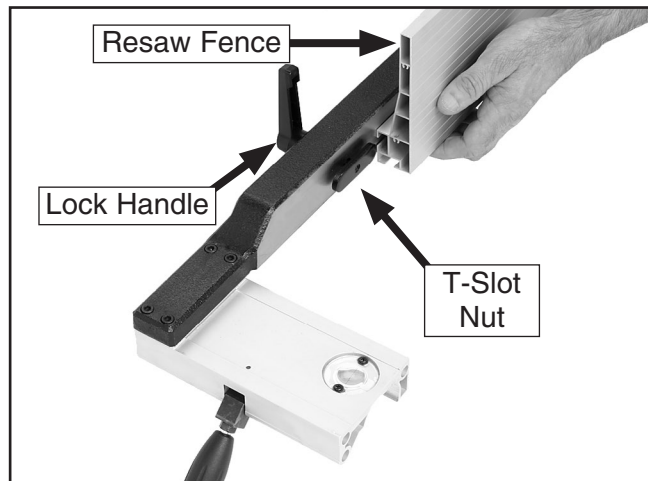

Figure 15. Attaching resaw fence to standard fence.

- Pull the fence lock lever up and place the fence assembly on the front rail, as shown in **Figure 16**.



Figure 16. Correctly installed fence.

- Adjust the rail pad against the rear rail until there is an even gap between the bottom of the fence and the table, then tighten the rail pad hex nut against the fence to secure the rail pad in place.
- Slide the fence against the blade.
- Place a straightedge across the table and line it up over the fence scale indicator line.
- Move the fence out of the way and carefully make a pencil mark on the front rail, using the straightedge as a guide. This mark will be used to line up the zero mark on the scale in the next step.

- Carefully install the scale on the front fence rail, so the 0" mark on the scale lines up with the pencil mark made in **Step 23**. Accuracy in this step is extremely important.

Note: After adhering the scale, you can adjust the position of the front rail slightly in either direction to increase the accuracy.

CAUTION

This saw creates substantial amounts of fine dust while operating. Failure to use a vacuum system can result in respiratory illness.

- Fit a 4" dust hose or 4" adapter over each dust port and secure in place with hose clamps, as shown in **Figure 17**.

Note: A tight fit is necessary for proper performance.

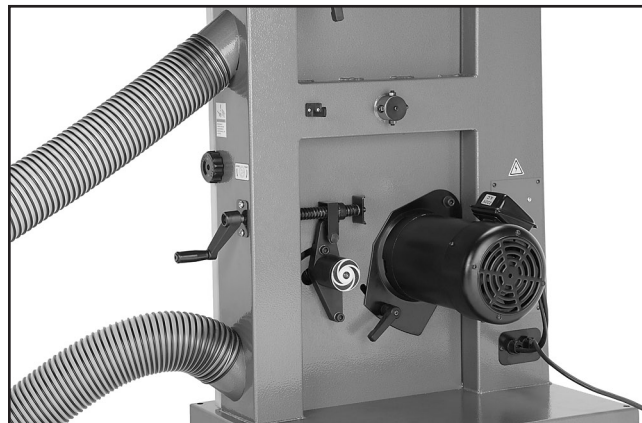

Figure 17. Dust hoses attached to dust ports.

- If cutting both wood and metal, connect this machine to a shop vacuum rather than a dust collector. Most dust collectors are not designed to capture metal shavings and doing so may lead to a fire from wood dust contacting hot metal cuttings or sparks from metal pieces hitting a dust collector impeller.

CAUTION

Mixing wood dust and metal cuttings may cause a fire. Do not collect metal shavings in a regular wood dust collector. Instead use a shop vacuum to collect metal cuttings.



Blade Tracking

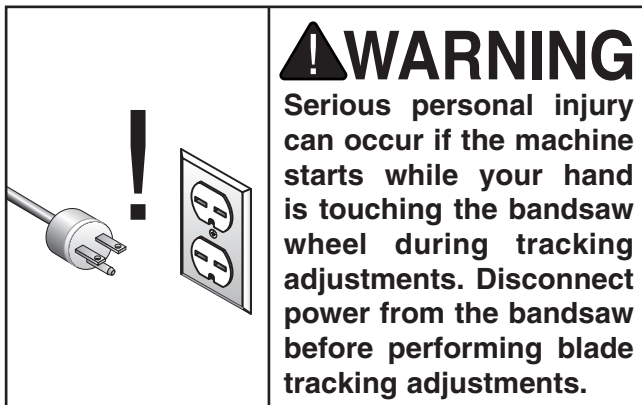

"Blade Tracking" refers to how the blade rides on the wheels. When tracking correctly, the blade rides in the center of the rim part of the wheels.

Blade tracking is primarily controlled by adjusting the upper wheel tilt. Tracking the blade in this manner is referred to as "Center Tracking," because you tilt the wheel until the blade rides in the center.

Another way to track the blade is known as "Coplanar Tracking." Coplanar tracking involves aligning the wheels so they are parallel and aligned (see **Wheel Alignment** on **Page 47**). When wheels are coplanar, vibration and heat are reduced during operation.

The wheels on the Model G0640X are factory aligned, so center tracking is the only adjustment that needs to be performed during setup.

To center track the blade:

1. DISCONNECT BANDSAW FROM POWER!
2. Make sure the upper and lower blade guides are adjusted away from the blade.
3. Engage the quick tension lever and turn the blade tension handwheel until the tension scale (**Figure 18**) reads between 4 and 6.

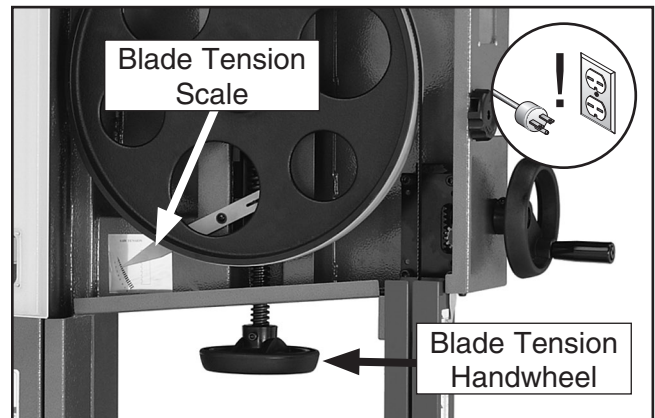

Figure 18. Blade tensioning controls.

! CAUTION

The cast iron spokes may have sharp edges and the blade teeth may extend beyond the edge of the wheel, creating a laceration hazard. In the next step, be careful when turning the wheel by hand.

4. Spin the upper wheel by hand at least three times and watch how the blade rides on the crown of the wheel. Refer to **Figure 19** for an illustration of this concept.

—If the blade rides in the center of the upper wheel and is centered on the peak of the wheel crown, then the bandsaw is already tracked properly and no further adjustments are needed at this time.

—If the blade does not ride in the center of the upper wheel and is not centered on the peak of the wheel crown, then continue with the following steps.

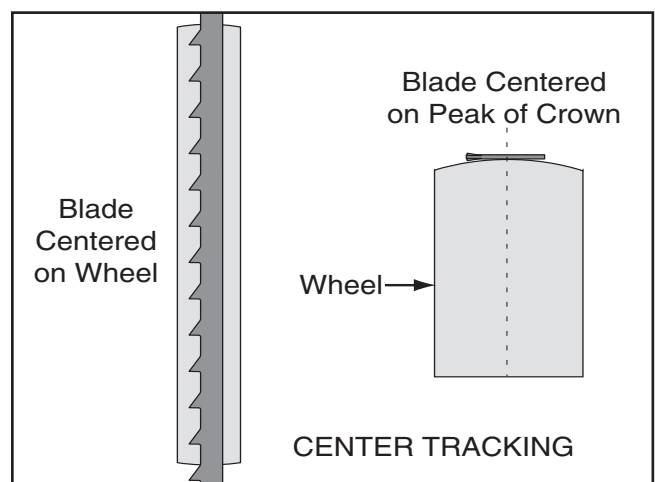

Figure 19. Center tracking profiles.



- Loosen the lock lever shown in **Figure 20** so that the blade tracking knob can rotate.

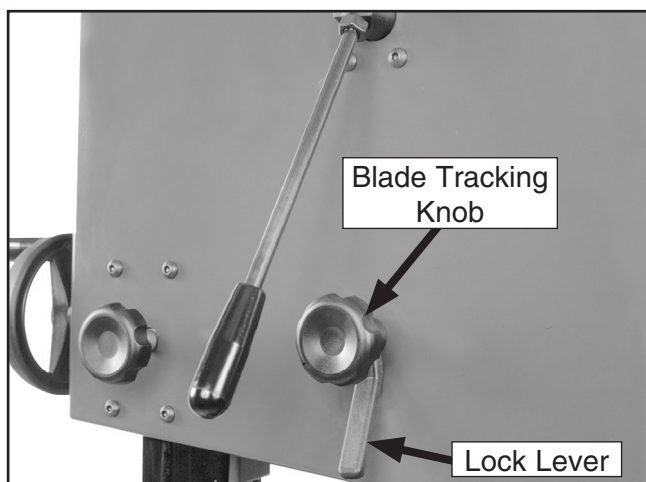

Figure 20. Blade tracking controls.

- Spin the upper wheel with one hand and slowly rotate the tracking control knob with the other hand to make the blade ride in the center of the bandsaw wheel tire.
- Close the upper wheel cover.
- Fine tune the blade tracking (as instructed in the following **Test Run** procedure) while the bandsaw is running, then tighten the lock lever attached to the blade tracking knob.

NOTICE

Changes in the blade tension may change the blade tracking.

Test Run

Once the assembly is complete, test run your machine to make sure it runs properly and is ready for regular operation.

The test run consists of verifying the following:
 1) The motor powers up and runs correctly, and
 2) the key switch shuts off power to the machine when in the off position.

If, during the test run, you cannot easily locate the source of an unusual noise or vibration, stop using the machine immediately, then review **Troubleshooting** on **Page 44**.

If you still cannot remedy a problem, contact our Tech Support at (570) 546-9663 for assistance.

To test run the machine:

- Make sure you have read the safety instructions at the beginning of the manual and that you have followed all previous setup instructions in this section.
- Make sure all tools and objects used during setup are cleared away from the machine and that the wheel covers are closed and latched.
- Connect the machine to the power source.
- Lower the upper blade guide assembly to approximately 1" over the table.
- Turn the variable speed dial counterclockwise (toward the SLOW side) all the way.
- Turn the power key switch to the ON position.
- Press START, allow the bandsaw to run for two seconds, then press STOP. This will give the blade enough time to start tracking off the wheel if the tracking is set incorrectly.
- Look through the blade tracking window (see **Figure 21**) and notice the position of the blade on the wheel.



Figure 21. Blade tracking window.



—If the blade is positioned in the center of the wheel, continue to the next step.

—If the blade is positioned near the edge of one side of the wheel, then the tracking needs to be adjusted before continuing. Disconnect the saw from power and repeat the **Blade Tracking** instructions on **Page 17**.

9. Turn the bandsaw **ON** and watch the blade through the blade tracking window. SLOWLY adjust the tracking knob until the blade rides in the center of the wheel, then tighten the lock lever attached to the blade tracking knob.
10. Turn the variable speed to the FAST direction to make sure the blade speed increases, then return the variable speed dial all the way to the SLOW position.
11. Turn the machine **OFF** by pressing the STOP button.

Note: *The power key switch is provided to restrict unauthorized users from operating the bandsaw. It is not intended as a way for stopping the bandsaw during regular operation.*

12. Turn the power key switch to the OFF position.
13. Test the power key switch by pressing the START button. The bandsaw should not operate while the power key switch is in the OFF position.

Note: *Although the power key switch prevents the machine from starting, it will not completely cut all power to the machine. Do not rely on the power key switch to disconnect the bandsaw from power for service, adjustments, or maintenance. Instead, you must physically unplug the power cord to disconnect the machine from power.*

If the previous tests were successful, the **Test Run** procedure is complete.

Blade Tensioning

A properly tensioned blade is essential for making accurate cuts and is required before making many bandsaw adjustments. (Every time you replace the blade, perform this procedure because all blades tension differently.) The numbers on the tension scale are arbitrary, but help you keep track of different tensions for different blades.

To tension the bandsaw blade:

1. Complete the **Test Run** procedure and make sure the blade is tracking properly.
2. Raise the upper blade guide assembly as high as it will go, and adjust the upper and lower blade guides at least a ¼" away from the blade.
Note: *This procedure will NOT work if the blade guides are close to the blade.*
3. Engage the quick tension lever to the tightened position and turn the blade tension handwheel until the tension scale is at 5.
4. Turn the bandsaw **ON**.
5. Slowly release the tension one quarter of a turn at a time. When you see the bandsaw blade start to flutter, stop decreasing the tension.
6. Now, slowly increase the tension until the blade stops fluttering, then tighten the tension another quarter turn.
7. Look at what the tension gauge reads and use that as a guide for tensioning that blade in the future.

Note: *Always untension the blade after use to increase bearings and blade lifespan.*

8. Re-adjust the blade tracking as instructed on **Page 17**.

NOTICE

To reduce blade stretching, remove tension from the blade when not in use.



Adjusting Blade Guides

The blade guides provide side-to-side support to help keep the blade straight while cutting. The blade guides are designed to be adjusted in two ways—forward/backward and side-to-side.

To adjust the upper and lower blade guides:

1. Make sure the blade is tracking properly and that it is correctly tensioned.
2. DISCONNECT BANDSAW FROM POWER!
3. Familiarize yourself with the upper blade guide controls shown in **Figure 22**.

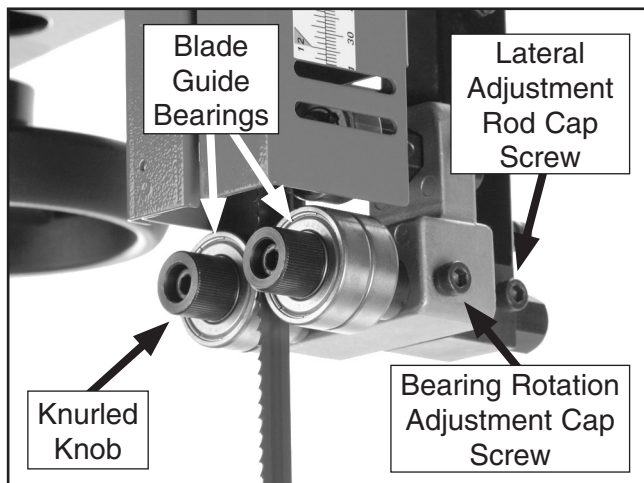

Figure 22. Blade guide controls.

4. Loosen the cap screw on the lateral adjustment rod and adjust the blade guides until the edges of the bearings are $\frac{1}{16}$ " behind the blade gullets, as illustrated in **Figure 23**.

Note: The $\frac{1}{16}$ " spacing is ideal, although with larger blades it may not be possible. In such cases, adjust the guide bearings as far forward as possible to the blade gullets, and still maintain the proper support bearing spacing adjustment.

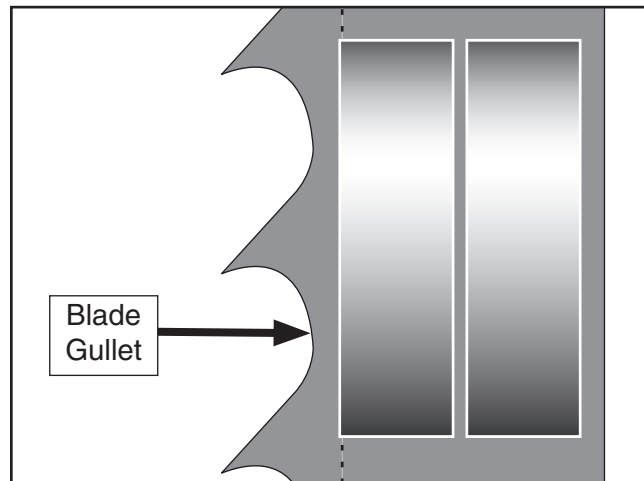

Figure 23. Lateral adjustment of blade guides.

NOTICE

Make sure that the blade teeth will not contact the guide bearings when the blade is against the rear support bearing during the cut or the blade teeth will be ruined.

5. Tighten the cap screw on the lateral adjustment rod.
6. Loosen the bearing rotation adjustment cap screws.
7. Use the knurled knob to rotate the bearings 0.004" away from the blade.

Note: 0.004" is approximately the thickness of a dollar bill.

8. Tighten the cap screw to lock the blade guide bearings in position.
9. Repeat this procedure for the lower guides. (All though the lower guides are set up a little differently, the concept is the same.)

NOTICE

Whenever changing a blade or adjusting tension and tracking, the upper and lower blade support bearings and guide bearings must be properly adjusted before cutting operations.



Adjusting Support Bearings

NOTICE

Whenever changing a blade or adjusting tension and tracking, the upper and lower blade support bearings and blade guide bearings must be properly adjusted before cutting operations.

The support bearings are positioned behind the blade for support during cutting operations. Proper adjustment of the support bearings is an important part of making accurate cuts and also keeps the blade teeth from coming in contact with the guide bearings while cutting.

To adjust the support bearings:

1. Make sure the blade is tracking properly and that it is correctly tensioned.
2. DISCONNECT BANDSAW FROM POWER!
3. Familiarize yourself with the upper support bearing controls shown in **Figure 24**.

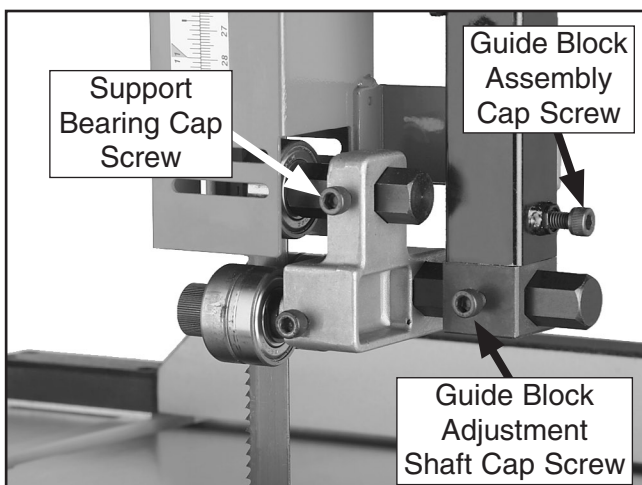

Figure 24. Upper support bearing controls.

4. Check that the blade is approximately 90° to the face of the support bearing as illustrated in **Figure 25** (it is not critical that it be precisely 90°—just make sure it is close.)

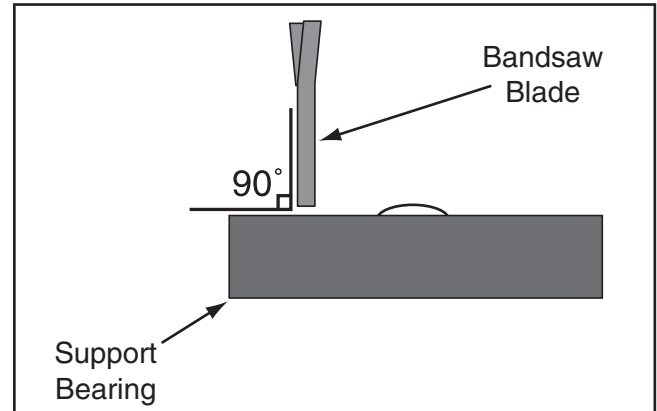

Figure 25. Blade should be perpendicular (90°) to the face of the support bearing.

—If the support bearing is 90° to the blade, no adjustment to the guide block rotation is necessary.

—If the support bearing is not 90° to the blade, loosen the two guide block assembly cap screws, rotate the blade guide assembly side-to-side, until the blade is 90° to the face of the support bearing as illustrated in **Figure 25**, then tighten the guide block assembly cap screws and re-adjust the blade guides.

5. Loosen the support bearing cap screw.
6. Place a 0.016" feeler gauge between the support bearing and the blade, and position the bearing 0.016" away from the back of the blade as illustrated in **Figure 26**.

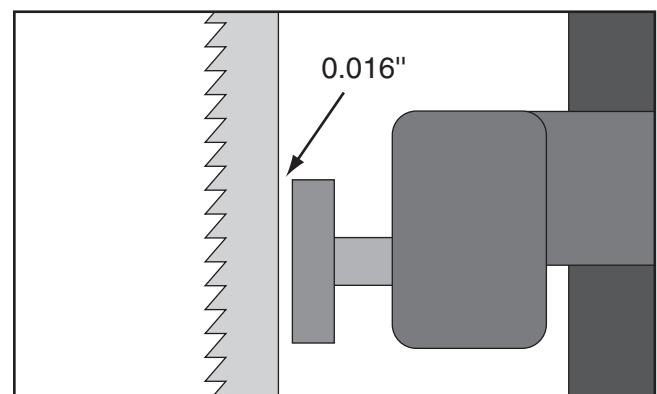

Figure 26. Blade should be aligned approximately 0.016" away from the bearing edge.



Note: For a quick gauge, fold a dollar bill in half twice (four thicknesses of a dollar bill is approximately 0.016") and place it between the support bearing and the blade as shown in **Figure 27**.

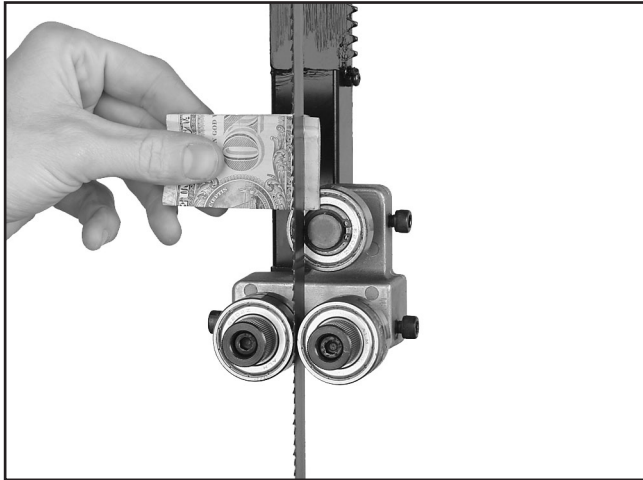

Figure 27. Dollar bill folded twice to make an approximate 0.016" gauge.

7. Tighten the support bearing cap screw.

To adjust the lower support bearings:

1. Make sure the blade is tracking properly and that it is correctly tensioned.
2. DISCONNECT BANDSAW FROM POWER!
3. Familiarize yourself with the lower support bearing controls shown in **Figure 28**.

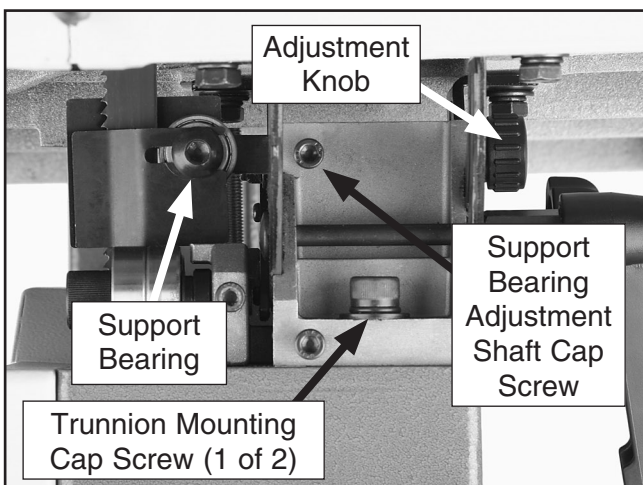

Figure 28. Lower support bearing controls.

4. Check to make sure the support bearing is positioned directly behind the blade.

—If the support bearing is positioned directly behind the blade, continue on to the next step.

—If the support bearing is not positioned directly behind the blade, loosen the trunnion mounting cap screws and shift the trunnion assembly over until the support bearing is behind the blade.

Note: The table must be re-aligned with the blade if the trunnion assembly is moved. Refer to **Page 23**.

5. Loosen the cap screw on the support bearing adjustment shaft.
6. Place a 0.016" feeler gauge between the support bearing and the blade, and use the adjustment knob to position the bearing 0.016" away from the back of the blade (similar to **Figure 26**) or use a dollar bill (**Figure 27**) instead of a feeler gauge.
7. Tighten the cap screw to keep the support bearing locked in place.

Adjusting Positive Stop

An adjustable positive stop allows the table to easily return to 90° after tilting. After adjusting the positive stop to 90°, the pointer on the table tilt scale should be adjusted to the 0° mark to ensure that the table tilt scale is accurate.

To set the positive stop 90° to the blade:

1. Make sure the blade is correctly tensioned as described in the **Blade Tensioning** instructions on **Page 19**.
2. DISCONNECT BANDSAW FROM POWER!



3. Loosen the lock handle that secures the table trunnions.
4. Loosen the hex nut that locks the positive stop bolt in place.
5. Raise the upper blade guide assembly and place a 6" machinist's square or try-square on the table next to the side of the blade, as illustrated in **Figure 29**. Adjust the positive stop bolt to raise or lower the table until the table is 90° to the blade.

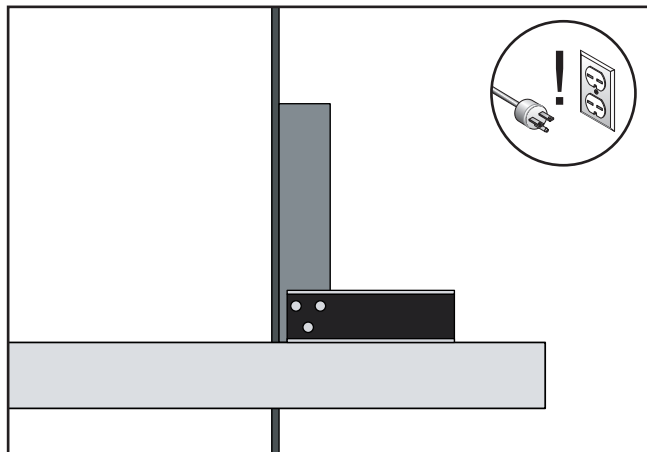

Figure 29. Squaring table to blade.

6. Tighten the lock handle, and lock the positive stop bolt by tightening the hex nut against the casting. *Ensure that the bolt does not turn by holding it with another wrench while tightening the hex nut.*
7. Loosen the pointer screw at the table tilt scale.
8. Align the tip of the pointer with the 0° mark on the table tilt scale.
9. Tighten the pointer screw.

Aligning Table

To ensure cutting accuracy when the table is first installed, the table should be aligned so that the miter slot is parallel to the bandsaw blade. This procedure works best with a 3/4" blade installed.

To align the table so the miter slot is parallel to the bandsaw blade:

1. Make sure that the blade is tracking properly and that it is correctly tensioned.
2. **DISCONNECT BANDSAW FROM POWER!**
3. Loosen the table mounting bolts that secure the trunnions to the table.
4. Place a straightedge on the table, so it lightly touches both the front and back of the blade.

Note: *Make sure the straightedge fits between the teeth so the tooth set does not skew it.*

5. Use a fine ruler to gauge the distance between the straightedge and the miter slot. The distance you measure should be the same at both the front and the back of the table (see **Figure 30**).

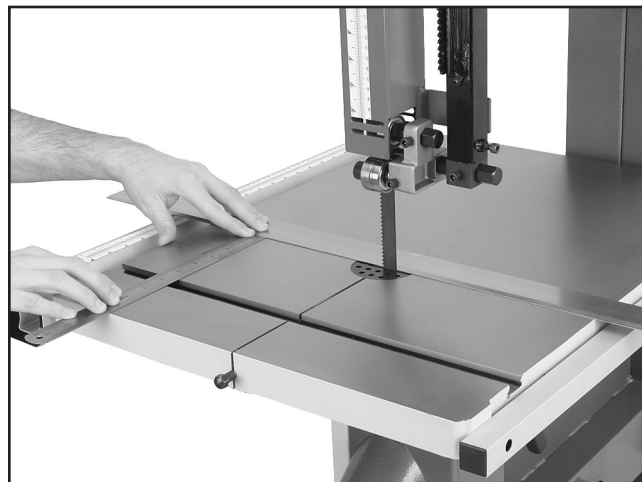

Figure 30. Measuring for miter slot to be parallel with blade.

6. Adjust the table as needed for proper alignment.
7. Tighten the table mounting bolts.



Aligning Fence

The fence must be parallel to the miter slot in order to yield accurate results.

To check/align the fence parallel with the miter slot:

1. Mount the fence next to the miter slot and examine the edges of each.
 - If the fence is parallel with the miter slot, then no adjustments are necessary.
 - If the fence is NOT parallel with the miter slot, continue to **Step 2**.
2. Loosen the four cap screws located on the top face of the fence (**Figure 31**).

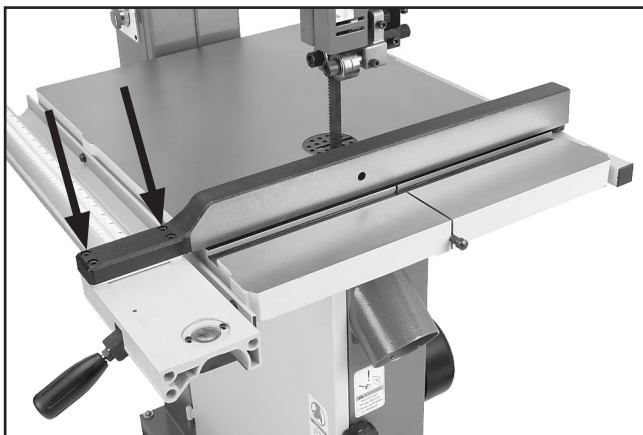

Figure 31. Four fence cap screws.

3. Adjust the fence face parallel with the edge of the miter slot.
4. Tighten the four cap screws, being careful not to move the fence.

NOTICE

Adjusting the fence parallel to the miter slot does not guarantee straight cuts. The miter slot may need to be adjusted parallel to the side of the blade, which is covered in the Aligning Table instructions on Page 23.

Miter Gauge

The miter gauge needs to be calibrated to the blade when it is first mounted in the miter slot.

To calibrate the miter gauge:

1. Place a machinist's square on the table so one edge is evenly touching the blade face, as shown in **Figure 32**, and the other edge is touching the miter gauge.

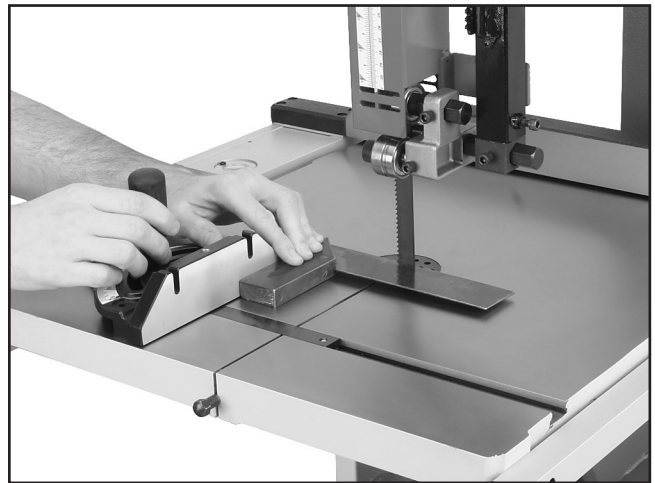

Figure 32. Squaring miter gauge to blade.

2. Loosen the lock knob on the miter gauge and adjust it until flush with the edge of the square.
3. Tighten the lock knob, and verify the setting.

Note: *Sometimes the tightening procedure can affect the adjustment.*

4. Adjust the stop screw and related lock nut on the underside of the miter gauge. This stop screw allows the miter gauge to return to the exact measurement repeatedly without using the square.
5. Loosen the screw that secures the angle pointer and adjust the pointer to the 0° mark on the scale.
6. Retighten the screw that secures the angle pointer.
7. Repeat **Steps 1–4** with the two 45° stops, using a 45° square as a gauge.



SECTION 4: OPERATIONS

Operation Safety

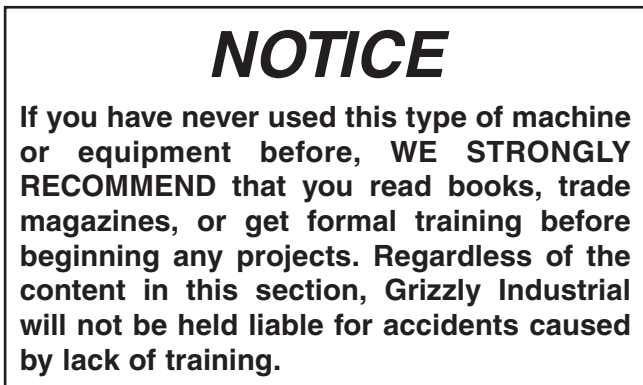
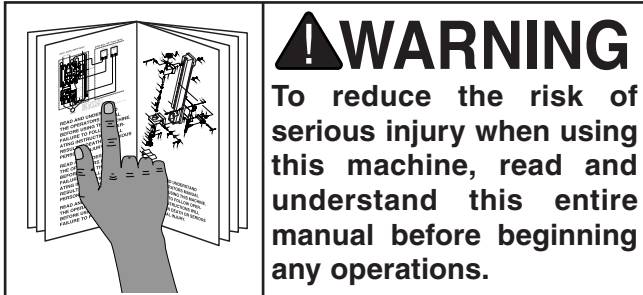

Guide Post

The guide post, shown in **Figure 33**, connects the upper blade guide assembly to the bandsaw. The guidepost allows the blade guide assembly to move up or down via a rack and pinion. In order to cut accurately, the blade guide assembly must be no more than $\frac{1}{4}$ " from the top of the workpiece at all times—this positioning provides the best support for the blade.

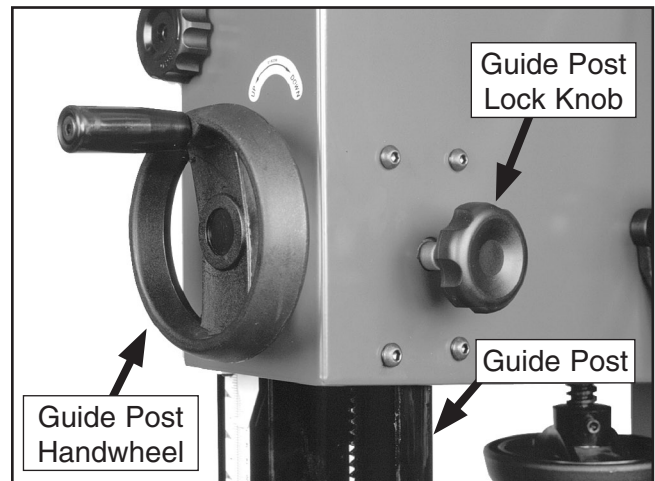

Figure 33. Guide post controls.

To adjust guide post:

1. Make sure that the blade tension, blade tracking, support bearing, and blade guides are adjusted correctly.
2. Loosen the guide post lock knob shown in **Figure 33**.
3. Turn the guide post handwheel to raise or lower the guide post until the upper blade guide assembly is within $\frac{1}{4}$ " from the top of the workpiece.
4. Lock the guide post in place with the lock knob.



Quick Release Blade Tension

Bandsaw blades stretch when tensioned and during operation. Eventually, an over-stretched blade will break. To minimize over-stretching, blade tension should always be removed after using the bandsaw.

The Model G0640X is equipped with a quick release blade tension device, which is controlled by the lever shown in **Figure 34**.

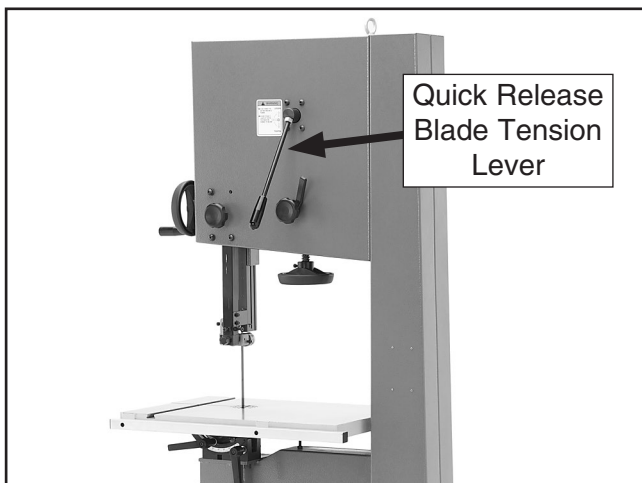
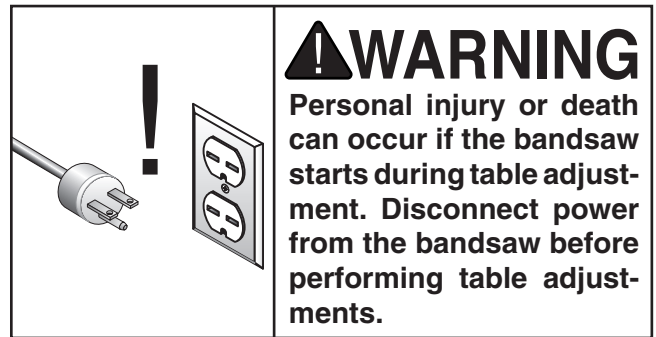

Figure 34. Quick release blade tension lever.

When the lever is pointed down, the blade is tensioned. When the lever is pointed up, the blade is not tensioned.

Once blade tension has been properly set for a certain blade (refer to **Page 19**), typically the lever can be used to tension/untension that blade without further adjustment with the blade tensioning knob.

Table Tilt



The bandsaw table will tilt 5° left and 45° right to provide a wide range of cutting options. Remove the positive stop bolt to tilt the table to the left.

To tilt the table:

1. DISCONNECT BANDSAW FROM POWER!
2. Loosen the lock handle on the table trunnion shown in **Figure 35**.

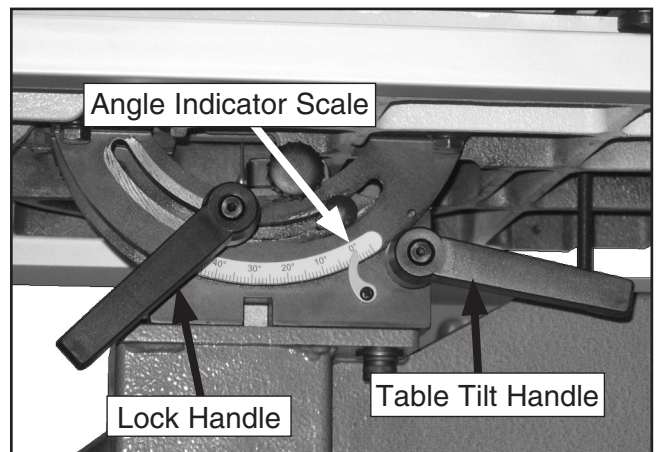

Figure 35. Table tilt controls.

3. Turn the table tilt handle to position the table to the desired angle of tilt. Refer to the angle gauge on the table trunnion scale for the tilting angle.
4. Retighten the lock handle to secure the table.



Blade Terminology

Selecting the right blade for the cut requires a knowledge of various blade characteristics.

Blade Terminology

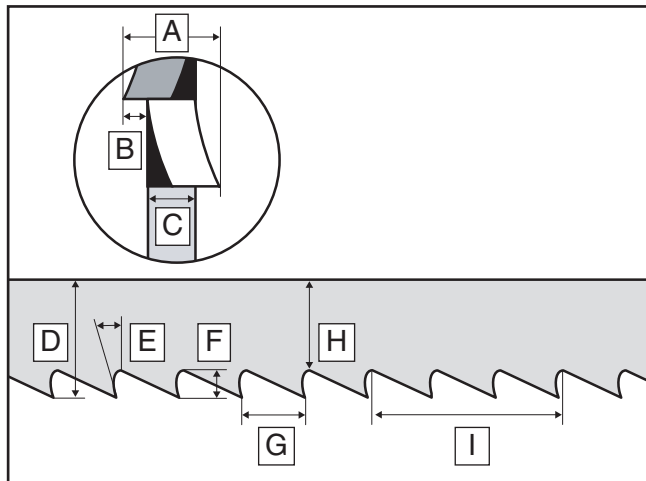

Figure 36. Bandsaw blade terminology.

- A. **Kerf:** The amount of material removed by the blade during cutting.
- B. **Tooth Set:** The amount each tooth is bent left or right from the blade.
- C. **Gauge:** The thickness of the blade.
- D. **Blade Width:** The widest point of the blade measured from the tip of the tooth to the back edge of the blade.
- E. **Tooth Rake:** The angle of the tooth from a line perpendicular to the length of the blade.
- F. **Gullet Depth:** The distance from the tooth tip to the bottom of the curved area (gullet).
- G. **Tooth Pitch:** The distance between tooth tips.
- H. **Blade Back:** The distance between the bottom of the gullet and the back edge of the blade.
- I. **TPI:** The number of teeth per inch measured from gullet to gullet.

Blade Selection

Selecting the right blade for the cut requires a knowledge of various blade characteristics. If you will be cutting metal, refer to **Page 37** for additional considerations.

Blade Length

Measured by the circumference of the band, blade length varies by saw.

Model	Blade Length
G0640X	131½"

Blade Width

Measured from the back of the blade to the tip of the blade tooth (the widest point), blade width is often the first consideration given to blade selection. Blade width dictates the largest and smallest curve that can be cut, as well as how accurately it can cut a straight line—generally the wider the blade, the straighter it will cut.

Model	Blade Width Range
G0640X	⅛"–1"

- **Curve Cutting:** Determine the smallest radius curve that will be cut on your workpiece and use the list below to select the correct blade width.

Blade Width	Radius
⅛"	⅛"
3/16"	3/8"
1/4"	5/8"
3/8"	1¼"
1/2"	2½"
5/8"	3¾"
3/4"	5½"

- **Straight Cutting:** Use the largest width blade that you own. Narrow blades can cut tight curves (a small radius) but are not very good at cutting straight lines because they naturally wander (blade lead). Wide blades excel at cutting straight lines and are less prone to wander.



Tooth Style

When selecting blades, another option to consider is the shape, gullet size, teeth set and teeth angle—otherwise known as “Tooth Style.” Many blade manufacturers offer variations of the four basic styles shown in **Figure 37**.

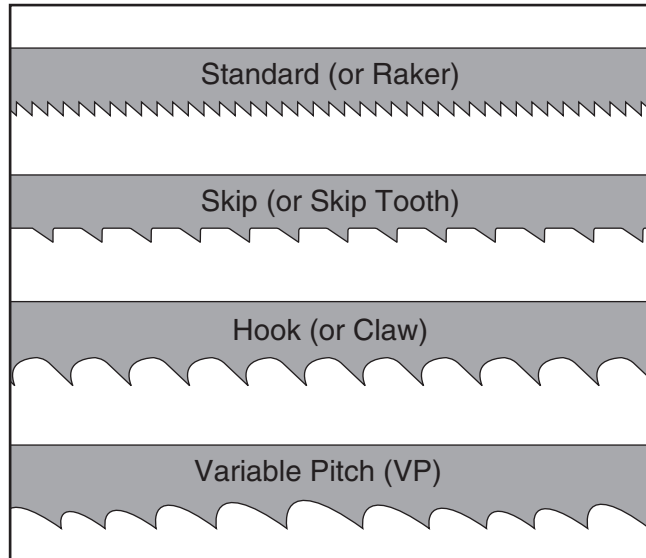

Figure 37. Bandsaw blade tooth types.

Standard: This style is considered to be the standard because the tooth size and shape are the same as the tooth gullet. The teeth on these blades usually are very numerous, have no angle, and produce cuts by scraping the material; these characteristics result in very smooth cuts, but do not cut fast and generate more heat than other types while cutting.

Skip: This style is similar to a raker blade that is missing every other tooth. Because of the design, skip toothed blades have a much larger gullet than raker blades, and therefore, cut faster and generate less heat. However, these blades also leave a rougher cut than raker blades.

Hook: The teeth on this style have a positive angle (downward) which makes them dig into the material, and the gullets are usually rounded for easier waste removal. These blades are excellent for the tough demands of resawing and ripping thick material.

Variable Pitch: These blades typically feature combinations of tooth styles that provide qualities of both.

Tooth Set

Three of the most common tooth sets are alternate, wavy, and raker (see **Figure 38**).

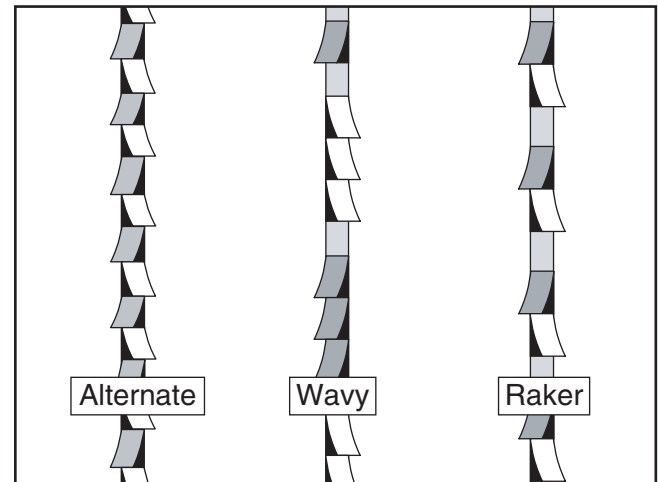

Figure 38. Bandsaw tooth sets.

Alternate: An all-purpose arrangement of bending the teeth evenly left and right of the blade. Generally used when exceptionally smooth, precise cuts are needed for cutting wood or mild steel.

Wavy: Generally three or more teeth in a group that are bent one way with a non-set tooth before the next group bent the other way. Typically used for straight cuts in thin metals or thin-wall tubing. Generally not used in woodworking.

Raker: There are three teeth in a recurring group—one bent left, next one bent right, and then a non-set tooth. The raker set is ideal for clearing chips on thick stock. It is often also used with contour, profile, and long cuts. This type of set leaves rough cut marks.

Tooth Pitch

Usually measured as TPI (teeth per inch), tooth pitch determines the size/number of the teeth. More teeth per inch (fine pitch) will cut slower, but smoother; while fewer teeth per inch (coarse pitch) will cut rougher, but faster. As a general rule, choose blades that will have at least three teeth in the material at all times. Use fine pitched blades on harder woods and metals and coarse pitched blades on softer woods and metals.



Blade Breakage

Many conditions may cause a bandsaw blade to break. Blade breakage is unavoidable, in some cases, since it is the natural result of the peculiar stresses that bandsaw blades must endure. Blade breakage is also due to avoidable circumstances. Avoidable blade breakage is most often the result of poor care or judgement on the part of the operator when mounting or adjusting the blade or support guides.

The most common causes of blade breakage are:

- Faulty alignment or adjustment of the blade guides.
- Forcing or twisting a wide blade around a short radius.
- Feeding the workpiece too fast.
- Dull or damaged teeth.
- Over-tensioned blade.
- Top blade guide assembly set too high above the workpiece. Adjust the top blade guide assembly so that there is approximately $\frac{1}{4}$ " between the bottom of the assembly and the workpiece.
- Using a blade with a lumpy or improperly finished braze or weld.
- Continuously running the bandsaw when not in use.
- Leaving the blade tensioned when not in use.
- Using the wrong pitch (TPI) for the workpiece thickness. The general rule of thumb is to have at least two teeth in contact with the workpiece at all times during cutting.

Blade Care & Break-In

Blade Care

A bandsaw blade is a delicate piece of steel that is subjected to tremendous strain. You can obtain longer use from a bandsaw blade if you give it fair treatment and always use the appropriate feed rate for your operation.

Be sure to select blades with the proper width, set, type, and pitch for each application. The wrong choice of blades will often produce unnecessary heat and will shorten the life of your blade.

A clean blade will perform much better than a dirty blade. Dirty or gummed up blades pass through the cutting material with much more resistance than clean blades. This extra resistance also causes unnecessary heat.

Blade Break-In

The sharp teeth tips and edges of a new blade are extremely sharp, and cutting at full feed rate may cause fracturing of the beveled edges of the teeth and premature blade wear.

To properly break-in a new blade:

1. Choose the correct speed for the blade and material of the operation.

Note: *We strongly recommend using mild steel if cutting metal during the break-in phase.*
2. Reduce the feed pressure by $\frac{1}{2}$ for the first 50–100 in² of material cut.
3. To avoid twisting the blade when cutting, adjust the feed pressure when the total width of the blade is in the cut.
4. (For Metal Cutting Only) Use the **Chip Inspection Chart** on **Page 38** to check the blade efficiency for metal cutting.



Blade Changes

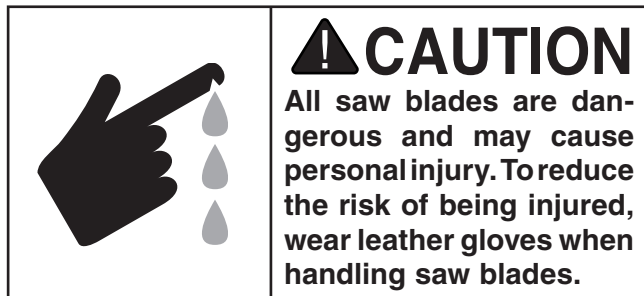
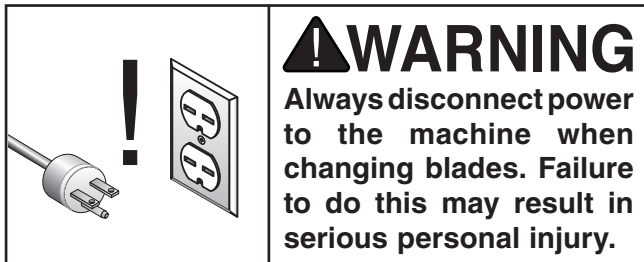

To remove a blade:

1. DISCONNECT BANDSAW FROM POWER!
2. Release the blade tension by pointing the blade tension quick release lever up.
3. Remove the table insert and the table pin. Adjust the upper and lower guide bearings as far away as possible from the blade.
4. Open the upper and lower wheel covers, and with gloved hands, slide the blade off of both wheels.
5. Rotate the blade 90° and slide it through the slot in the table.

To replace a blade:

1. Slide the blade through the table slot, ensuring that the teeth are pointing down toward the table.

Note: *If the teeth will not point downward in any orientation, the blade is inside-out. Put on heavy gloves, remove the blade, and twist it right side-out.*

2. Slip the blade through the guides, and mount it on the upper and lower wheels (**Figure 39**).

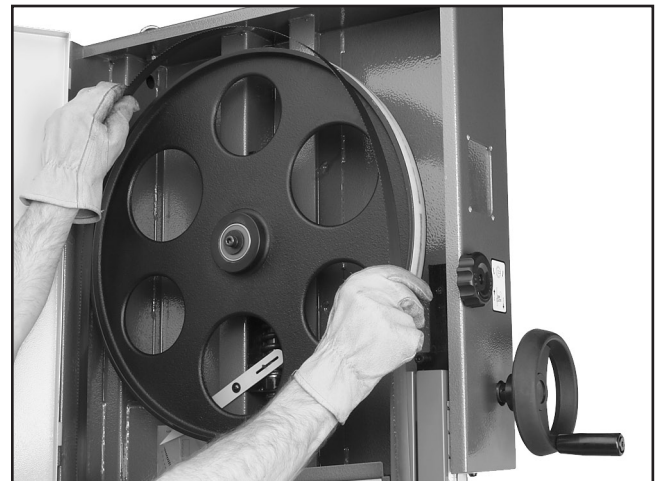

Figure 39. Placing blade on the wheels.

3. Tighten the blade tension lever by pointing it down.
4. Apply tension to the blade by turning the tension control knob. Rotate the upper wheel slowly by hand as tension is applied to allow the blade to center itself on the wheel. Adjust tracking if needed.
5. Adjust tension as described **Page 19**.
6. Adjust the upper/lower guide bearings and the support bearings, as described in **Pages 20–21**.
7. Close the wheel covers.
8. Replace the table insert and table pin, being sure not to use excessive force when inserting the table pin.



Blade Speed

This bandsaw features a variable blade speed between 100–3600 FPM. There are two blade speed ranges. A fast range for wood cutting and a slow range for metal cutting.

The variable speed dial controls the blade speed within each range. The position of the V-belts behind the lower wheel cover control which speed range is activated. A disc with a spiral shape is located near the motor as a reminder to the operator which blade speed range is engaged. The disc spins when the metal cutting speed range is engaged.

The V-belt tension is controlled in two ways, depending on which position it is in. When in the "wood" position, the V-belt tension is controlled by the position of the motor, which pivots to tension/loosen the belt.

At "metal" position, the V-belt tension is controlled by the hand crank located between the dust ports.

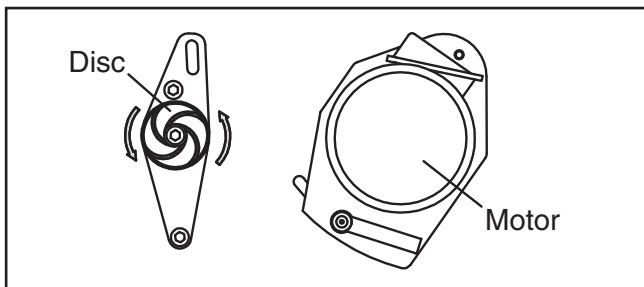

Figure 40. Spiral disc near motor (spins when belts are positioned for metal cutting).

To change the V-belt positions:

1. DISCONNECT BANDSAW FROM POWER!
2. Open the lower wheel cover.
3. Loosen the V-belt tension.
4. Refer to **Figure 41** to locate the correct V-belt position for the desired speed range.

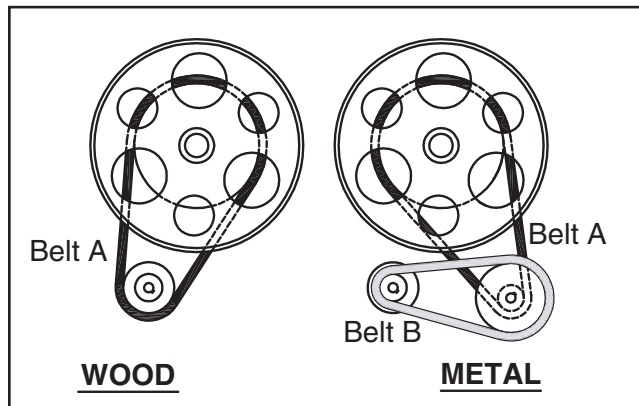

Figure 41. V-belt positions for speed ranges.

5. Move the V-belt(s) to the desired position.
6. Tension the V-belt(s) to deflect approximately $\frac{1}{2}$ " (see **Figure 42**).

Note: If one belt is used more than the other belt, it will stretch slightly under normal conditions. This means that one belt may be looser than the other when both belts are installed. This is normal. Overtightening one belt in attempt to tighten the other will decrease the lifespan of the bearings in the pulleys.

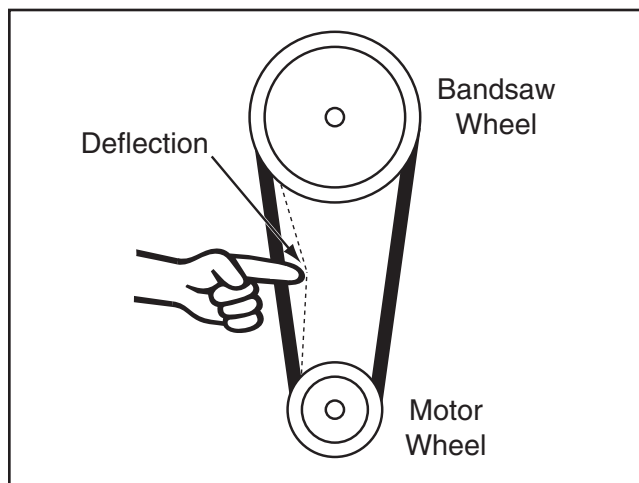

Figure 42. V-belt deflection.

7. Close all wheel covers.
8. Press the button below the "Blade Speed" digital display to light up either the "Wood" or "Metal" light so it matches your V-belt setting.



SECTION 5: WOOD CUTTING

Workpiece Inspection

Some wood workpieces are not safe to cut or may require modification before they are safe to cut.

Before cutting wood, get in the habit of inspecting all workpieces for the following:

- **Foreign Objects:** Nails, staples, dirt, rocks and other foreign objects are often embedded in wood. While cutting, these objects can become dislodged and hit the operator or break the blade, which might then fly apart. Always visually inspect your workpiece for these items. If they cannot be removed, do NOT cut the workpiece.
- **Large/Loose Knots:** Loose knots can become dislodged during the cutting operation. Large knots can cause blade damage. Choose workpieces that do not have large/loose knots or plan ahead to avoid cutting through them.
- **Wet or "Green" Stock:** Cutting wood with a moisture content over 20% causes unnecessary wear on the blade and yields poor results.
- **Excessive Warping:** Workpieces with excessive cupping, bowing, or twisting are dangerous to cut because they are unstable and can move unpredictably when being cut. DO NOT use workpieces with these characteristics!
- **Minor Warping:** Workpieces with slight cupping can be safely supported if the cupped side faces the table or fence. On the contrary, a workpiece supported on the bowed side will rock during a cut, leading to loss of control.

Cutting Tips

- Keep the upper blade guide assembly adjusted to within 1/4" of the workpiece.
- Replace, sharpen, and clean blades as necessary. Make adjustments periodically to keep the saw running in top condition.
- Use light and even pressure while cutting. Light contact with the blade makes it easier to follow lines and prevents extra friction.
- Avoid twisting the blade when cutting around tight corners. Allow the blade to saw around the corners.
- Misusing the saw or using incorrect techniques is unsafe and results in poor cuts. Remember—the blade does the cutting with the operator's guidance.
- Never start a cut with the blade in contact with the workpiece, and do not start a cut on a sharp edge.
- Use the right blade for the cutting task.
- Avoid cutting round objects, such as dowels, that cannot be properly supported or locked in place against the miter gauge. Unsupported round pieces can entangle your hands in the moving blade, causing serious injury.



Ripping

Ripping is the process of cutting with the grain of the wood stock. For plywood and other processed wood, ripping simply means cutting down the length of the workpiece.

To make a rip cut:

1. Adjust the fence to match the width of the cut on your workpiece and lock the fence in place.
2. Adjust the blade guide assembly to the correct height.
3. After all safety precautions have been met, turn the bandsaw **ON**. Slowly feed the workpiece into the blade and continue with the cut until the blade is completely through the workpiece. **Figure 43** shows a typical ripping operation.

Note: *If you are cutting narrow pieces, use a push stick to protect your fingers.*



Figure 43. Ripping with a push stick.

Crosscutting

Crosscutting is the process of cutting across the grain of wood. For plywood and other processed wood, crosscutting simply means cutting across the width of the material.

To make a 90° crosscut:

1. Mark the workpiece on the edge where you want to begin the cut.
2. Adjust the blade guide assembly to the correct height and make sure the miter gauge is set to 90°.
3. Move the fence out of the way. Place the workpiece evenly against the miter gauge.
4. Hold the workpiece against the miter gauge and line up the mark with the blade.
5. After all safety precautions have been met, turn the bandsaw **ON**. Slowly feed the workpiece into the blade and continue the cut until the blade is all the way through the workpiece. **Figure 44** shows a typical crosscutting operation.

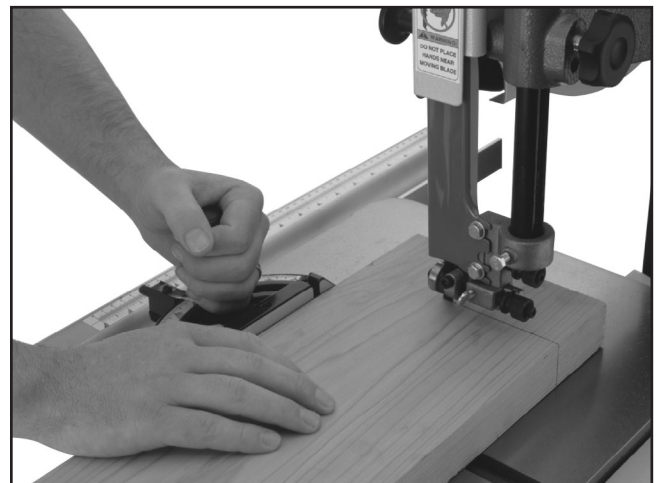

Figure 44. Crosscutting with miter gauge.



Resawing

Resawing (**Figure 45**) is the process of cutting a board into two or more thinner boards. The maximum board width that can be resawn is limited by the maximum cutting height of the bandsaw.

One of the most important considerations when resawing is blade selection. Generally, wide blades are best for resawing. In most applications, a hook or a skip tooth style will be desirable. Choose blades with fewer teeth-per-inch (from 3 to 6), because they have larger gullets for clearing sawdust, reducing heat buildup, and reducing strain on the motor.

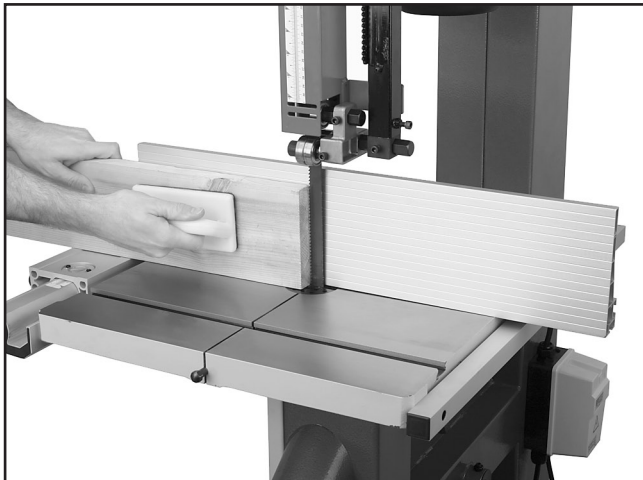

Figure 45. Resawing lumber.

!WARNING

When resawing thin pieces, a wandering blade (blad lead) can tear through the surface of the workpiece, exposing your hands to the blade teeth. Always use push blocks when resawing and keep your hands clear of the blade.

To resaw a workpiece:

1. Verify that the bandsaw is setup properly and that the table is perpendicular to the blade.
2. Use the widest blade your bandsaw will accept.

Note: *The blade must also be sharp and clean.*

3. Install the resaw fence and set it to the desired width of cut and lock it in place.

NOTICE

The scale on the front rail will NOT be accurate when using the resaw fence.

4. Support the ends of the board if necessary.
5. Turn the bandsaw **ON**.
6. Using push paddles and a push stick, keep pressure against the fence and table, and slowly feed the workpiece into the moving blade until the blade is completely through the workpiece (see **Figure 45**).



Stacked Cuts

One of the benefits of a bandsaw is its ability to cut multiple copies of a particular shape by stacking a number of workpieces together. Before making stacked cuts, ensure that both the table and the blade are properly adjusted to 90°. Otherwise, any error will be compounded.

To complete a stacked cut:

1. Align your pieces from top to bottom to ensure that each piece has adequate scrap to provide a clean, unhampered cut.
2. Secure all the pieces together in a manner that will not interfere with the cutting. Hot glue on the edges works well, as do brad nails through the waste portion. (Be careful not to cut into the brads or you may break the blade!)
3. On the face of the top piece, lay out the shape you intend to cut.
4. Make relief cuts perpendicular to the outline of your intended shape in areas where changes in blade direction could strain the woodgrain or cause the blade to bind.
5. Cut the stack of pieces as though you were cutting a single piece. Follow your layout line with the blade kerf on the waste side of your line, as shown in **Figure 46**.

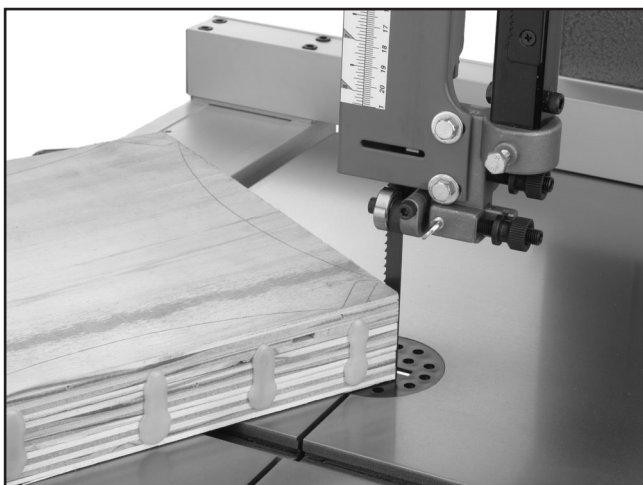

Figure 46. Typical stacked cut.

Cutting Curves

When cutting curves, simultaneously feed and turn the stock carefully so that the blade follows the layout line without twisting. If a curve is so abrupt that you must repeatedly back up and cut a new kerf, use a narrower blade, a blade with more TPI (teeth per inch), or make more relief cuts.

Always make short cuts first, then proceed to the longer cuts. Relief cuts will also reduce the chance that the blade will be pinched or twisted. Relief cuts are cuts made through the waste portion of the workpiece and are stopped at the layout line. As you cut along the layout line, waste wood is released from the workpiece, alleviating any pressure on the back of the blade.

Cutting Circles

Bandsaws can cut circles with the use of a shop-built or aftermarket jig. Typically, these jigs work on the same principal as a drafting compass.

Figure 47 below shows a generic shop built jig that can be easily made of wood, dowels, and wood screws. To set it up, advance the jig forward until the stop dowel hits the table, then pencil a square "radius" line across the jig. A nail can be placed anywhere on the radius line, depending on the size of the desired circle. Draw an X across the bottom of the workpiece and drill a small pivot hole in the center of the X to place on the nail. Place the workpiece on the nail, advance the jig to the stop dowel, place rear dowel, then cut circle.

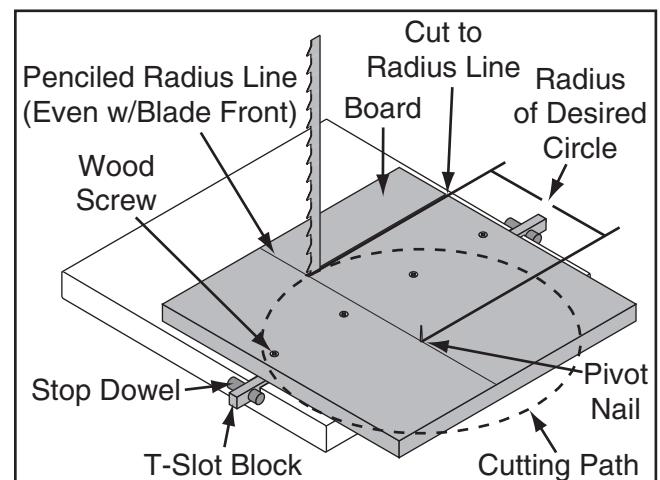

Figure 47. Example shop-built circle cutting jig.



SECTION 6: METAL CUTTING

Workpiece Inspection

Some metal workpieces are not safe to cut with a vertical metal cutting bandsaw; instead, a different tool or machine should be used.

Before cutting, inspect the material for any of the following conditions and take the necessary precautions:

- **Small or Thin Workpieces:** Small or thin workpieces are dangerous to cut if held by hand—avoid cutting these workpieces if possible. If you must cut a small or thin workpiece, attach it to or clamp it between larger scrap pieces that will both support the workpiece through the cut and keep your fingers away from the blade. Some thin sheet metals will not withstand the forces from this bandsaw during cutting; instead, use a shear, nibblers, or sheet metal nippers to cut these pieces.
- **Round/Unstable Workpieces:** Workpieces that cannot be properly supported or stabilized without a vise should not be cut on a vertical metal-cutting bandsaw. Examples are chains, cables, round or oblong-shaped workpieces, workpieces with internal or built-in moving or rotating parts, etc.
- **Material Hardness:** Always factor in the hardness of the metal before cutting it. Hardened metals will take longer to cut, may require lubrication, and may require a different type of blade in order to efficiently cut them.
- **Tanks, Cylinders, Containers, Valves, Etc:** Cutting into containers that are pressurized or contain gasses or liquids can cause explosions, fires, caustic burns, or machine damage. Avoid cutting any of these types of containers unless you have verified that the container is empty and it can be properly supported during a cut.
- **Magnesium:** Pure magnesium burns easily. Cutting magnesium with a dull blade can create enough friction to ignite the small magnesium chips into a fire. Avoid cutting magnesium if possible.

Cutting Tips

- Keep the upper blade guide assembly adjusted to within $\frac{1}{4}$ " of the workpiece.
- Avoid overheating your blade. Keep an oil can nearby and squirt the blade near the cutting area when it gets hot or you see a small amount of smoke. Different metals require different types and amounts of lubrication.
- Replace, sharpen, and clean blades as necessary. Make adjustments periodically to keep the saw running in top condition.
- Use light and even pressure while cutting. Light contact with the blade makes it easier to follow lines and prevents extra friction.
- Avoid twisting the blade when cutting around tight corners. Allow the blade to saw around the corners.
- Misusing the saw or using incorrect techniques is unsafe and results in poor cuts. Remember—the blade does the cutting with the operator's guidance.
- Never start a cut with the blade in contact with the workpiece, and do not start a cut on a sharp edge.
- Pay attention to the characteristics of the chips when cutting—they are good indicators of proper blade speed and feed rate. **Page 38** shows the basic chip characteristics and what they mean.
- Use the right blade for the cutting task.



Choosing Blades and Speeds

Selecting the right blade for the job depends on a variety of factors, such as type of material being cut, hardness of the material, material shape, machine capability, and operator technique.

The chart below is a basic starting point for choosing blade type based on teeth per inch (TPI) for variable tooth pitch blades and for standard raker type bi-metal blades/HSS blades. However, for exact specifications of bandsaw blades, contact the blade manufacturer.

To select the correct blade TPI:

1. Measure the material thickness. This measurement is the length of cut taken from where the tooth enters the workpiece, sweeps through, and exits the workpiece.

2. Refer to the "Material Width/Diameter" row of the blade selection chart in **Figure 48** and read across to find the workpiece thickness you need to cut.
3. Refer to the "Material Shapes" row and find the shape and material to be cut.
4. In the applicable row, read across to the right and find the box where the row and column intersect. Listed in the box is the minimum TPI recommended for the variable tooth pitch blades.
5. The "Cutting Speed Rate Recommendation" section of the chart offers guidelines for various metals, given in feet per minute (speed FPM) and meters per minute in parenthesis.

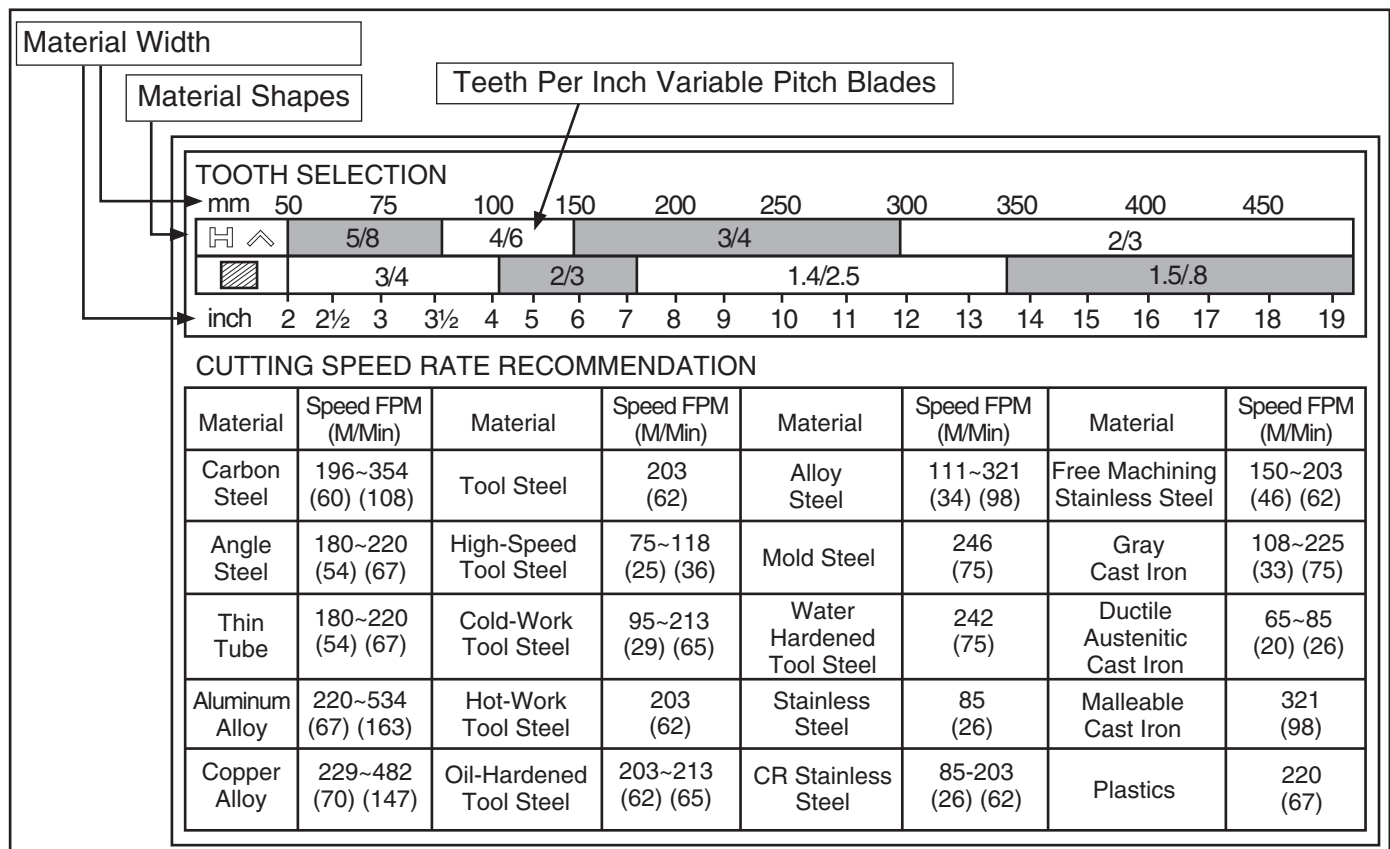

Figure 48. Blade selection and speed chart for metal cutting.



Metal Chip Inspection Chart

The best method of evaluating the performance of your metal cutting operation is to inspect the chips that are formed from cutting. Refer to the chart below for chip inspection guidelines.





Chip Appearance	Chip Description	Chip Color	Blade Speed	Feed Pressure	Additional Actions
	Thin & Curled	Silver	<i>Good</i>	<i>Good</i>	
	Hard, Thick & Short	Brown or Blue	Decrease	Decrease	Lubricate with a small amount of oil
	Hard, Strong & Thick	Brown or Blue	Decrease	Decrease	Lubricate with a small amount of oil
	Hard, Strong & Thick	Silver or Light Brown	<i>Good</i>	Decrease Slightly	Check Blade Pitch
	Hard & Thin	Silver	Increase	Decrease	Check Blade Pitch
	Straight & Thin	Silver	<i>Good</i>	Increase	
	Powdery	Silver	Decrease	Increase	
	Curled Tight & Thin	Silver	<i>Good</i>	Decrease	Check Blade Pitch

Figure 49. Chip inspection chart.



SECTION 7: ACCESSORIES

Replacement Blades

These replacement blades are milled for exact tooth set and are made with high quality tool steel.

131½" Carbon Steel Replacement Blades

MODEL	WIDTH	TPI & TYPE
H4803	⅛"	14 RAKER
H4804	¼"	6 HOOK
H4805	¼"	18 RAKER
H4806	⅜"	10 RAKER
H4807	½"	6 HOOK
H4808	½"	10 RAKER
H4809	¾"	3 HOOK
H4810	1"	6 HOOK
H4811	1"	2 HOOK

131½" Timber Wolf® Bandsaw Blades

MODEL	WIDTH	TPI & TYPE
H8591	⅛"	14 HIGH PERFORMANCE
H8592	¼"	4 POSITIVE CLAW
H8593	¼"	10 RAKER
H8594	⅜"	4 POSITIVE CLAW
H8595	⅜"	10 RAKER
H8596	½"	3 POSITIVE CLAW
H8597	½"	10 RAKER
H8598	¾"	3 ALT. SPECIAL RESAW
H8599	1"	3 POSITIVE CLAW

131½" Metal Cutting Bandsaw Blades

MODEL	WIDTH	TPI & TYPE
T20349	1"	3-4 VARIABLE PITCH
T20224	1"	4-6 VARIABLE PITCH
T20225	1"	5-8 VARIABLE PITCH
T20226	1"	6-10 VARIABLE PITCH
T20227	1"	8-12 VARIABLE PITCH

G7315—Heavy-Duty SHOP FOX® Mobile Base

Make your machine mobile with this popular patented mobile base. The unique outrigger type supports increase stability and lower machine height. This heavy duty mobile base is rated for up to a 1300 lb. capacity.



Figure 50. G7315 SHOP FOX® Mobile Base.

H7873—Ceramic Blade Guide Set

These Euro-style ceramic guides run cool, are extremely wear resistant, and offer superior blade support for precision cutting. Set includes both upper and lower guide blocks.

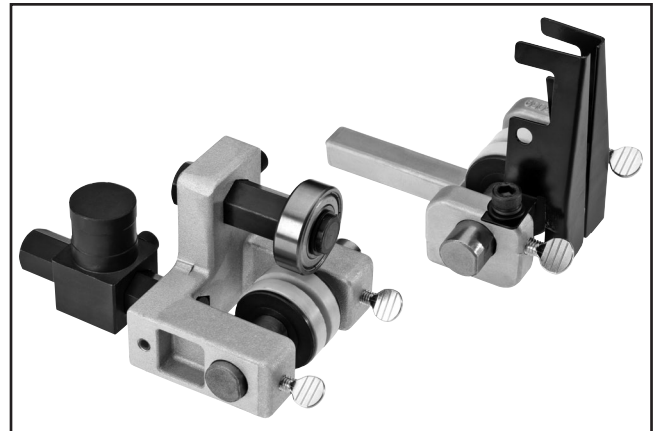

Figure 51. H7873 Ceramic Blade Guide Set.

Call 1-800-523-4777 To Order



- T20501—Face Shield, 4" Crown, Clear
- T20502—Face Shield, 7" Crown, Clear
- T20448—Economy Clear Safety Glasses
- T20452—"Kirova" Anti-Reflective Glasses
- T20456—"Dakura" Clear Safety Glasses
- H0736—Shop Fox® Safety Glasses

These glasses meet ANSI Z87.1-2003 specifications. Buy extras for visitors or employees. You can't be too careful with shop safety!

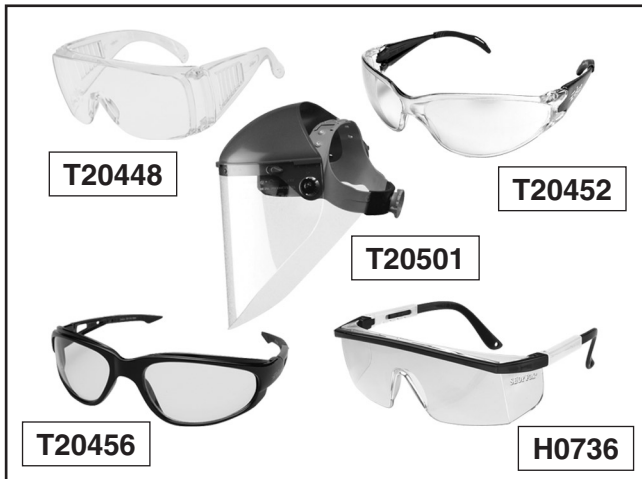

Figure 52. Our most popular eye protection.

G1928—Bandsaw Handbook

This is the bandsaw bible. Covers step-by-step instructions for basic/advanced cutting techniques. Also includes advanced maintenance, service and troubleshooting procedures, as well as information on bandsaw history/design and blade metallurgy. 320 pages.

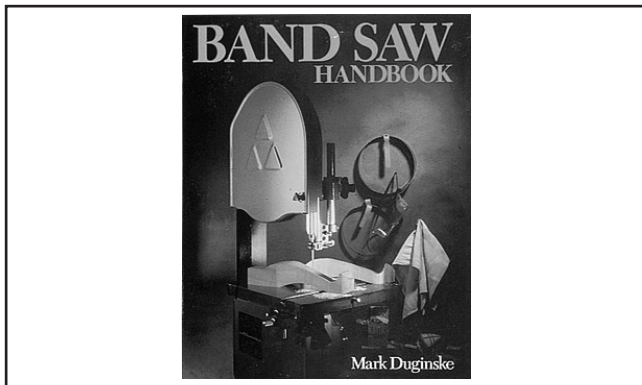

Figure 53. Bandsaw handbook.

Call 1-800-523-4777 To Order

- T20514—Small Half-Mask Respirator
 - T20515—Medium Half-Mask Respirator
 - T20516—Large Half-Mask Respirator
 - T20511—Pre-Filter P100
 - T20539—Cartridge Filter 2PK P100
 - T20541—Cartridge Filter 2PK P100 & O Vapor
- Wood and other types of dust can cause severe respiratory damage. If you work around dust every-day, a half-mask respirator can greatly reduce your risk. Compatible with safety glasses!

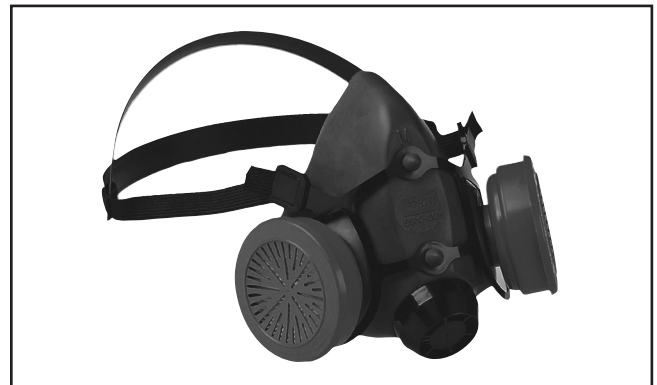

Figure 54. Half-mask respirator with disposable cartridge filters.

- G5562—SLIPIT® 1 Qt. Gel
- G5563—SLIPIT® 12 oz Spray
- G2871—Boeshield® T-9 12 oz Spray
- G2870—Boeshield® T-9 4 oz Spray
- H3788—G96® Gun Treatment 12 oz Spray
- H3789—G96® Gun Treatment 4.5 oz Spray



Figure 55. Recommended products for protecting unpainted cast iron/steel on machinery.



SECTION 8: MAINTENANCE



Schedule

For optimum performance from your machine, follow this maintenance schedule and refer to any specific instructions given in this section.

Daily

- Check/tighten loose mounting bolts.
- Check for a dull or damaged saw blade and replace if necessary.
- Check for worn or damaged wires and replace if necessary.
- Check for and remedy any other unsafe condition.
- Clean inside and outside of bandsaw, then wipe down unpainted cast iron surfaces.
- Untension blade after shutting bandsaw down for the day.

Monthly

- Check for V-belt damage.
- Grease guide post gears.

Quarterly

- Grease blade tension leadscrew.
- Grease belt tension crank leadscrew.
- Grease table trunnions.

Cleaning

Vacuum cutting chips and dust from in and on the bandsaw, and wipe off the remaining dust with a dry cloth. If wood resin or lubricating oil has built up, use a resin dissolving or oil soluble cleaner to remove it. Once a month, remove the blade and thoroughly clean all built-up particles from the rubber tires on the wheels.

Wheel Brush

The bandsaw is equipped with a lower wheel brush. The brush should be checked daily and cleaned when it becomes dirty. There is an adjustment bracket that allows the brush to be adjusted for bristle wear. Refer to **Adjusting Wheel Brush** on **Page 46** for adjustment details.

Lubrication

Tables, Fence, and Miter Gauge

After cleaning, wipe the unpainted cast iron surfaces on the table, fence, and miter gauge with regular applications of metal protectant lubricants such as G96® Gun Treatment, SLIPIT®, or Boeshield® T-9 (see **Page 39** for more details).

Continued on next page →



Guide Post Gears

1. DISCONNECT BANDSAW FROM POWER!
2. Lower the guide post down so the upper guide bearings almost touch the table, then open the upper wheel cover to access the gears, shown in **Figure 56**.

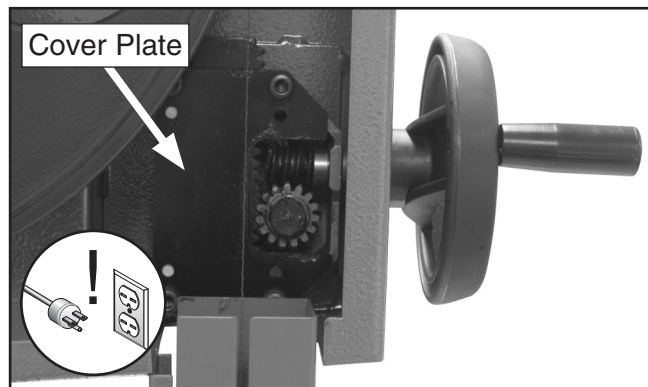

Figure 56. Guide post gears.

3. Use a 6mm hex wrench to remove the four cap screws that hold the cover plate in place. (The gears can be greased without removing the cover plate, but removing the cover plate makes cleaning easier.)
4. Wipe as much of the old grease off the gears as possible, and also wipe off the rack (the long plate with teeth that contact the pinion gear). The old grease will be contaminated with wood or metal dust, so you want to remove as much of it as possible.
5. Use mineral spirits or the degreaser shown in **Figure 4** on **Page 12** to clean any remaining grease from the gears and rack. Make sure to thoroughly wipe off the degreaser or mineral spirits after use so they won't contaminate the new grease.
6. Use a small, clean brush to apply automotive-grade multi-purpose grease to the pinion gear. After applying, rotate the handle two or three times to distribute the grease.
7. Coat the inside cover plate with a light layer of grease and replace it.
8. Close the upper wheel cover, and re-adjust the guide post height as necessary.

Blade and Belt Tension Leadscrews

1. DISCONNECT BANDSAW FROM POWER!
2. Wipe as much of the old grease off the leadscrews (**Figures 57 & 58**) as possible. The old grease will be contaminated with wood or metal dust, so you want to remove as much of it as possible.

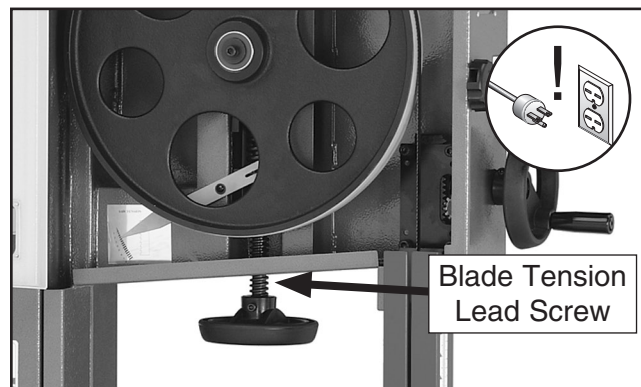

Figure 57. Blade tension leadscrew.

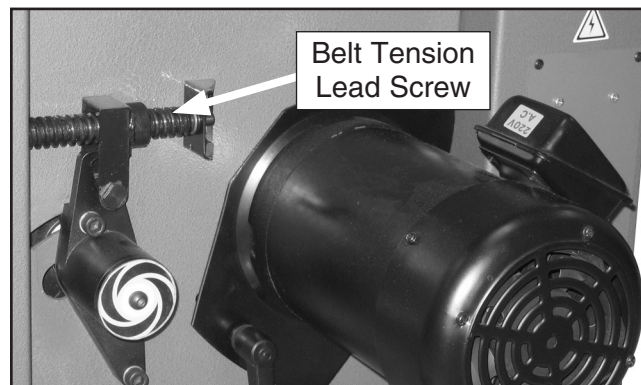

Figure 58. Belt tension crank leadscrew.

3. Use mineral spirits or the degreaser shown in **Figure 4** on **Page 12** to clean any remaining grease from the leadscrews. Make sure to thoroughly wipe off the degreaser or mineral spirits after use so they will not contaminate the new grease.
4. Use a small, clean brush to apply automotive-grade multi-purpose grease to the leadscrews. After applying, rotate the handles through their full range of motion to distribute the grease.
5. Close the upper wheel cover, and re-adjust the blade and belt tension as necessary.



Table Trunnions

1. DISCONNECT BANDSAW FROM POWER!
2. Wipe the old grease off the bearing surfaces of the table trunnions. Start with the outward side of the table trunnions (**Figure 59**) when the table is at 0°, then tilt the table to 45° and wipe off the inward side. The old grease will be contaminated with wood or metal dust, so you want to remove as much of it as you can.

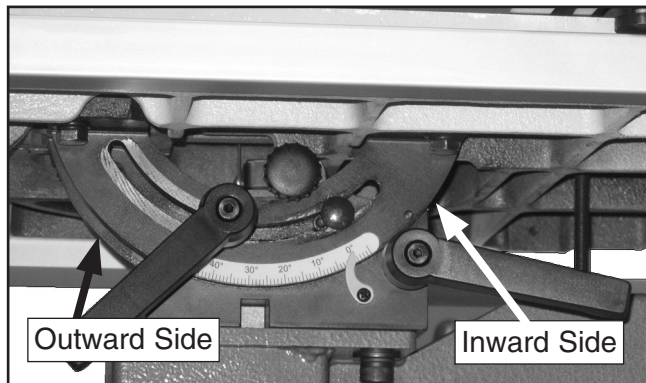

Figure 59. Sides of table trunnions to grease.

3. Use mineral spirits or the degreaser shown in **Figure 4** on **Page 12** to clean any remaining grease from the trunnions. Make sure to thoroughly wipe off the degreaser or mineral spirits after use so they won't contaminate the new grease.
4. Use a small, clean brush to apply automotive-grade multi-purpose grease to the trunnion bearing surfaces. After applying, tilt the table back and forth from 0° to 45° to distribute the grease.

Redressing Rubber Tires

As the bandsaw ages, the rubber tires on the wheels may need to be redressed if they harden or glaze over. Redressing the rubber tires improves blade tracking and reduces vibration/blade lead.

If the rubber tires become too worn, then blade tracking will become extremely difficult. At that point, redressing will no longer be effective and the rubber tires must be replaced.

To redress the rubber tires:

1. DISCONNECT BANDSAW FROM POWER!
2. Put on heavy leather gloves.
3. Remove the blade.
4. Clean any built-up sawdust from the rubber tires.
5. Hold 100 grit sandpaper against the rubber tire and rotate the wheel by hand. Only redress the rubber enough to expose a fresh rubber surface.



SECTION 9: SERVICE

Review the troubleshooting and procedures in this section to fix or adjust your machine if a problem develops. If you need replacement parts or you are unsure of your repair skills, then feel free to call our Technical Support at (570) 546-9663.

Troubleshooting

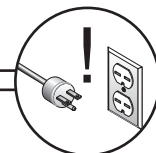

Motor & Electrical

Symptom	Possible Cause	Possible Solution
Machine does not start or a breaker trips.	<ol style="list-style-type: none"> 1. Key switch is turned off. 2. Plug/receptacle is at fault or wired incorrectly. 3. Motor connection wired incorrectly. 4. Wall fuse/circuit breaker is blown/tripped. 5. Power supply switched OFF or is at fault. 6. Wiring is open/has high resistance. 7. Motor START/STOP button or ON/OFF switch is at fault. 8. Inverter/Controller box is at fault. 9. Motor is at fault. 	<ol style="list-style-type: none"> 1. Turn key switch on. 2. Test for good contacts; correct the wiring. 3. Correct motor wiring connections. 4. Ensure circuit size is suitable for this machine; replace weak breaker. 5. Ensure power supply is switched on; ensure power supply has the correct voltage. 6. Check for broken wires or disconnected/corroded connections, and repair/replace as necessary. 7. Replace faulty START/STOP button or ON/OFF switch. 8. Inspect inverter/controller box; replace if faulty. 9. Test/repair/replace.
Machine stalls or bogs down while cutting.	<ol style="list-style-type: none"> 1. Feed rate/cutting speed too fast for task. 2. Machine is undersized for the task. 3. Blade is slipping on wheels. 4. Motor connection is wired incorrectly. 5. Plug/receptacle is at fault. 6. Pulley/sprocket slipping on shaft. 7. Motor is at fault. 	<ol style="list-style-type: none"> 1. Decrease feed rate/cutting speed. 2. Use sharp blade with lower TPI; reduce the feed rate/depth of cut. 3. Adjust blade tracking and tension to factory specifications; redress tires as stated on Page 43. 4. Correct motor wiring connections. 5. Test for good contacts; correct the wiring. 6. Replace loose pulley/shaft. 7. Test/repair/replace.
Machine has vibration or noisy operation.	<ol style="list-style-type: none"> 1. Motor or component is loose. 2. Blade weld is at fault or teeth are broken. 3. Blade is at fault. 4. V-belt worn or loose. 5. Pulley is loose. 6. Motor mount loose/broken. 7. Machine is incorrectly mounted or sits unevenly. 8. Motor fan is rubbing on fan cover. 9. Motor bearings are at fault. 	<ol style="list-style-type: none"> 1. Inspect/replace stripped or damaged bolts/nuts, and re-tighten with thread locking fluid. 2. Replace blade. 3. Replace warped, bent, or twisted blade; sharpen dull blade. 4. Inspect/replace belt. 5. Realign/replace shaft, pulley, setscrew, and key as required. 6. Tighten/replace. 7. Tighten/replace anchor studs in floor; relocate/shim machine. 8. Replace dented fan cover; replace loose/damaged fan. 9. Test by rotating shaft; rotational grinding/loose shaft requires bearing replacement.



Cutting Operations

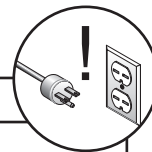

Symptom	Possible Cause	Possible Solution
Machine slows when operating.	<ol style="list-style-type: none"> 1. Feeding workpiece too fast. 2. Blade is dull. 	<ol style="list-style-type: none"> 1. Reduce feed rate. 2. Replace blade (Page 30).
Ticking sound when the saw is running.	<ol style="list-style-type: none"> 1. Blade weld contacting guide/support bearings (a light tick is normal). 2. Blade weld may be failing. 	<ol style="list-style-type: none"> 1. Use file or stone to smooth and round the back of the blade; slightly loosen the blade guides. 2. Inspect and replace blade if necessary (Page 30).
Blade contacting table insert.	<ol style="list-style-type: none"> 1. Insert installed upside down or backwards. 2. Table improperly mounted or aligned. 	<ol style="list-style-type: none"> 1. Re-install insert a different way. 2. Align table (Page 23).
Vibration when cutting.	<ol style="list-style-type: none"> 1. Loose or damaged blade. 2. Sawdust buildup on wheels. 	<ol style="list-style-type: none"> 1. Tighten or replace blade (Page 30). 2. Clean all sawdust from rubber tires on wheels.
Burn marks on the edge of the cut.	<ol style="list-style-type: none"> 1. Too much side pressure when feeding workpiece; blade is binding. 2. Blade too wide for size of radius being cut. 	<ol style="list-style-type: none"> 1. Feed workpiece straight into the blade. See Cutting Tips on Page 32. 2. Install a smaller width blade/increase blade tension. See Page 30.
Rough or poor quality cuts.	<ol style="list-style-type: none"> 1. Feeding workpiece too fast. 2. Blade guides adjusted incorrectly. 	<ol style="list-style-type: none"> 1. Reduce feed rate. 2. Re-adjust all blade guides and support bearings.
Sawdust buildup inside cabinet.	<ol style="list-style-type: none"> 1. Clogged dust port. 2. Low CFM (airflow) from the shop vacuum. 	<ol style="list-style-type: none"> 1. Clean out dust port. 2. Three options: <ul style="list-style-type: none"> —Check dust hoses for leaks or clogs. —Connect saw to a more powerful shop vacuum.
Blade wanders or doesn't cut straight.	<ol style="list-style-type: none"> 1. Blade lead. 2. Sawdust buildup on wheels. 	<ol style="list-style-type: none"> 1. Refer to Blade Lead on Page 49. 2. Clean all sawdust from rubber tires on wheels.
Cuts are not square (vertically).	<ol style="list-style-type: none"> 1. Table tilt is not adjusted to 0° or positive stop has moved out of adjustment. 2. Table tilt scale pointer is not calibrated. 3. Table is not square to the blade. 	<ol style="list-style-type: none"> 1. Adjust table tilt to 0°; re-adjust positive stop if necessary (Page 22). 2. Calibrate table tilt scale pointer to 0° as described in the Adjusting Positive Stop instructions on Page 22. 3. Shim table (Page 49).

Miscellaneous

Symptom	Possible Cause	Possible Solution
Blade tension scale is grossly inaccurate.	<ol style="list-style-type: none"> 1. The spring in the blade tension mechanism has lost its "spring." This is caused by not releasing the blade tension when not in use or frequently over-tensioning the bandsaw. 	<ol style="list-style-type: none"> 1. Replace spring in the blade tension mechanism, then take better care of the bandsaw by releasing tension when not in use and not over-tensioning the blade.
Wheel is noisy.	<ol style="list-style-type: none"> 1. Wheel bearing is worn out. 2. Belt is too tight (lower wheel). 	<ol style="list-style-type: none"> 1. Replace the wheel bearing. 2. Check/loosen the belt tension as described in the Blade Speed instructions on Page 31.
Blade does not track consistently, correctly, or at all.	<ol style="list-style-type: none"> 1. Wheels are not coplanar or aligned with each other. 2. Rubber tires on wheels are worn out. 	<ol style="list-style-type: none"> 1. Adjust wheels to be coplanar/aligned with each other (Page 47). 2. Redress the rubber tires on the wheels (Page 43); replace the rubber tires on the wheels.



Replacing V-Belts

To ensure optimum power transfer from the motor to the blade, the V-belts must be in good condition and operate under proper tension. Check belt tension at least every 3 months—more often if the bandsaw is used daily. V-belts stretch with use and must be periodically re-tensioned.

Replace the V-belts if they are cracked, frayed, or excessively worn.

To replace the V-belts:

1. DISCONNECT BANDSAW FROM POWER!
2. Open both wheel covers and remove the blade.
3. Unthread the wheel mount bolt shown in **Figure 60** and slide the lower wheel off of the bearing shaft.

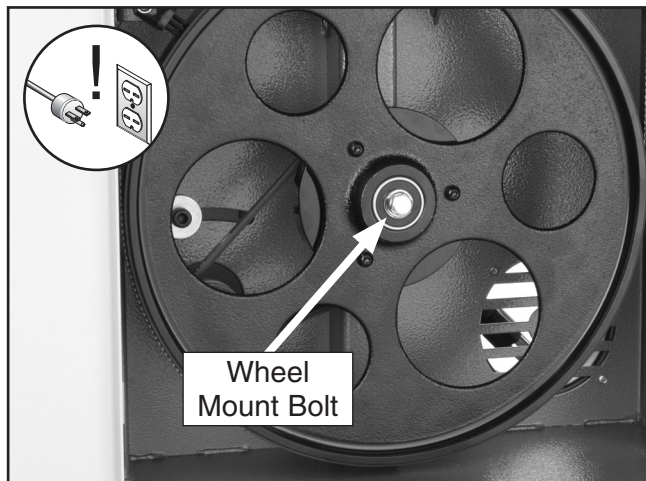

Figure 60. Wheel mount bolt.

4. Loosen the V-belts with the belt tension crank and roll them off of the pulleys.
5. Replace the V-belts and tension them as described in the **Blade Speed** section on **Page 31**.
6. Reinstall the lower wheel and blade, and close the wheel covers.

Adjusting Wheel Brush

The lower wheel compartment contains the wheel brush shown in **Figure 61**. This brush is designed to sweep sawdust off the wheel tire as the bandsaw is operating. In order to work properly the brush must be making contact with the wheel.

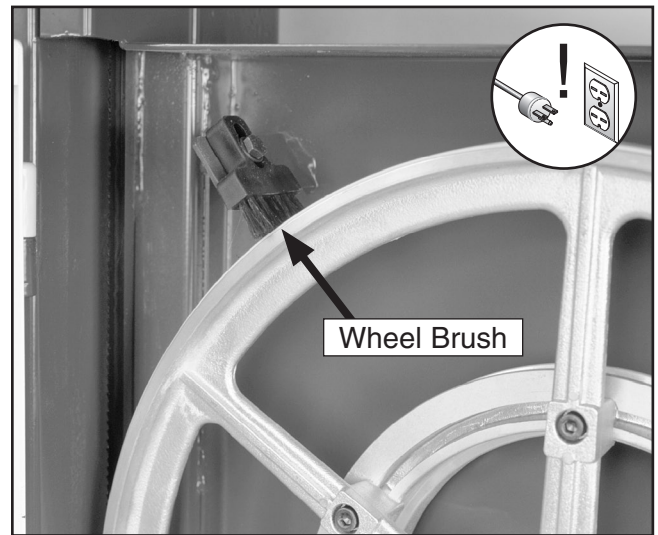

Figure 61. The wheel brush.

Tools Needed:

	QTY
Wrench/Socket 10mm	2

To adjust the wheel brush:

1. DISCONNECT BANDSAW FROM POWER!
2. Open the lower wheel cover.
3. Loosen the bolt/nut that secures the wheel brush in place.
4. Adjust the wheel brush so it makes good contact with the wheel.
5. Tighten the bolt/nut to secure the wheel brush in place.



Wheel Alignment

Components and Hardware Needed:	Qty
56" Long 2x4	1

Tools Needed:

Wrench 13mm	1
Tape Measure	1
Coplanarity Gauge (see Figure 62)	1

Wheel alignment is one of the most critical factors for optimal performance from your bandsaw.

Heat, vibration, wandering, blade wear, tire wear and overall bandsaw wear are considerably decreased when the wheels are properly aligned or "coplanar."

Coplanar wheels automatically track the blade by balancing it on the crown of the wheel. This is known as coplanar tracking.

To check if your wheels are coplanar:

1. Make the "Coplanarity Gauge" shown in **Figure 62**. **Note:** For best results, straighten the 2x4 with a jointer before cutting.
2. Remove the fence and table, then open both wheel covers.
3. Make sure the guide blocks and rear support bearings are away from the blade, then tighten your blade to the tension that will be used during operation.
4. Place your coplanarity gauge up against both wheels in the positions shown in **Figure 63**.

Continued on next page →

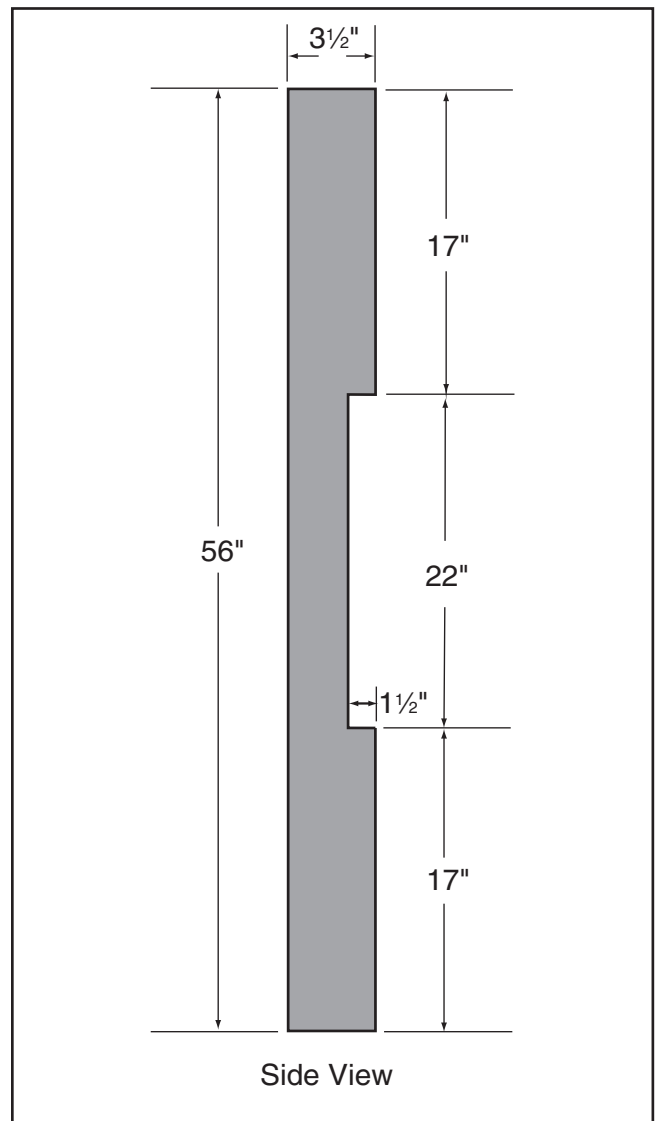

Figure 62. Dimensions of coplanarity gauge.

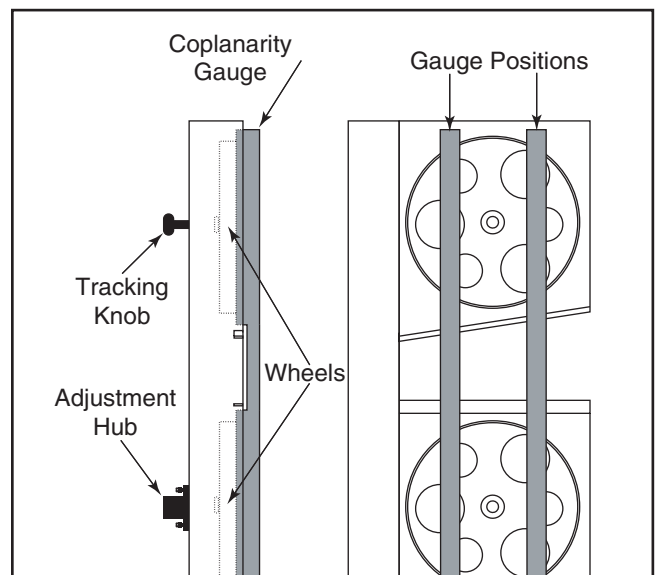

Figure 63. Checking for coplanarity.



5. Adjust the tracking knob to get both wheels parallel. If the wheels won't go parallel to each other, then move the lower wheel at the adjustment hub (**Figure 64**) so they line up.
6. If the wheels will go parallel but not coplanar, shim the required wheel out as necessary (not to exceed $\frac{3}{4}$ "), using thin $\frac{3}{4}$ " washers on the shaft behind the wheel.
7. **Figure 65** shows the positions of the wheels when coplanar. When your wheels are coplanar, re-adjust the guide blocks and rear support bearings, and replace the wheel covers.

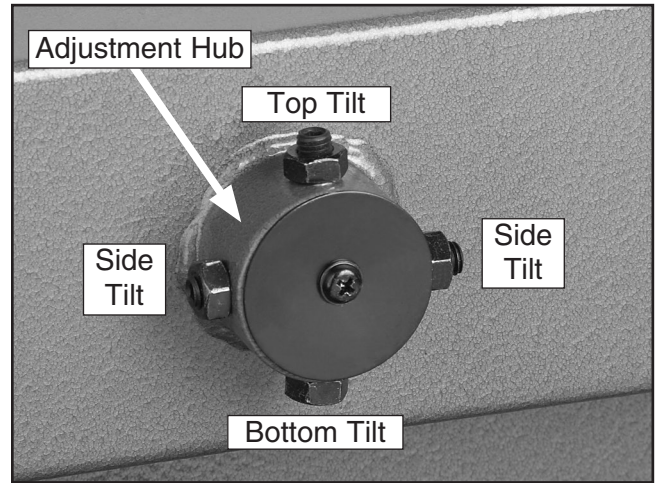

Figure 64. Lower wheel adjustment control.

Note: *The blade may track slightly off-center when the wheels are coplanar. This is natural because the blade will be balanced on the crown of the tire, rather than just in the center of the tire. This will be more noticeable with larger blades.*

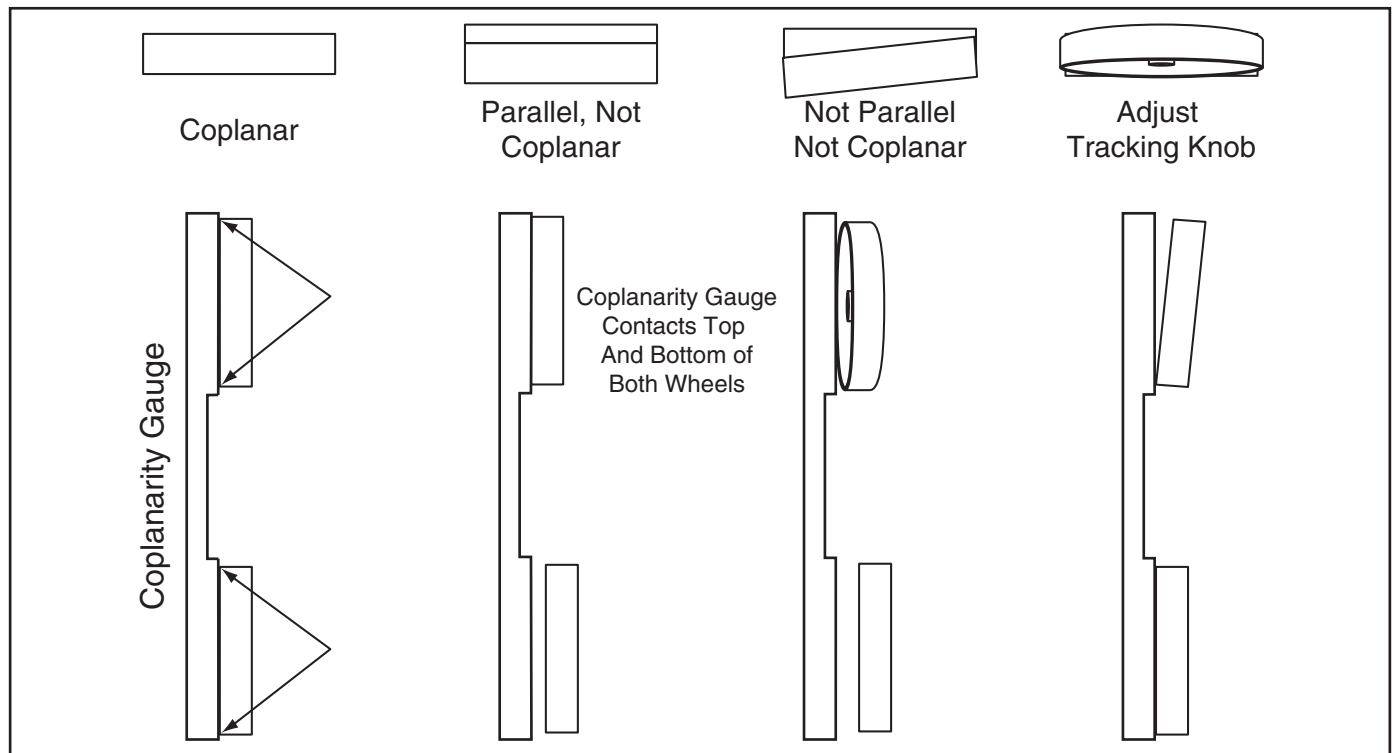

Figure 65. Coplanarity diagram.



Shimming Table

To ensure accuracy when cutting stacked workpieces, the table should be 90° to the back of the blade as shown in **Figure 66**. If the table is not perpendicular to the back of the blade, the table needs to be shimmed.

Shims can be made of any durable object that can be sandwiched between the table and the trunnions. We recommend using shim washers or shim stock because of the wide range of available thicknesses. These items can be purchased at your local hardware store.

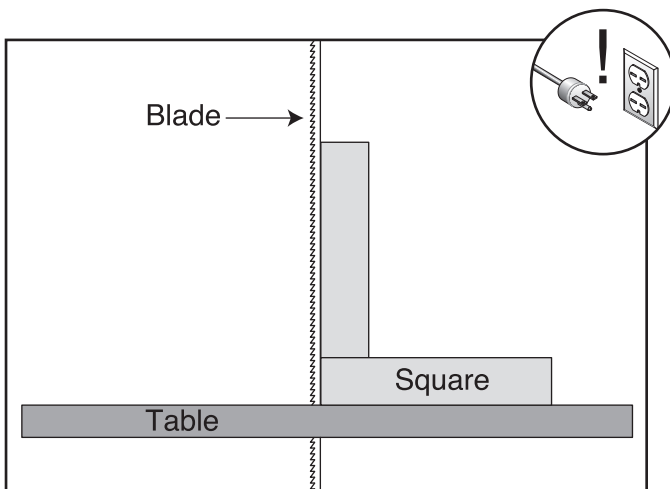

Figure 66. Squaring table to blade back.

To shim the table:

1. Make sure that the blade is tracking properly and that it is correctly tensioned.
2. **DISCONNECT BANDSAW FROM POWER!**
3. Loosen the table mounting bolts that secure the table to the trunnion.
4. Place shims between the table and the trunnion to position the table in the desired direction.
5. Follow the **Aligning Table** instructions on **Page 23** to complete this procedure.

Blade Lead

Bandsaw blades sometimes wander off the cut line when sawing, as shown in **Figure 67**. This is called blade lead. Blade lead is commonly caused by too fast of a feed rate, a dull or abused blade, or improper tension. If your blade is sharp/undamaged and you still have blade lead, perform the following instructions.



Figure 67. Blade leading away from line of cut.

To correct blade lead:

1. Use less pressure when feeding the workpiece through the cut.
2. Check that the miter slot or fence is parallel to the blade line, and correct if necessary.
3. Check for proper blade tension. If the blade tension is correct and it is not convenient to replace the blade, compensate for lead by skewing the fence or adjusting the table.

To skew your fence:

1. Cut a piece of scrap wood approximately 3/4" thick x 3" wide x 17" long. On a wide face of the board, draw a straight line parallel to the long edge.
2. Cut halfway through the board on the line by pushing it into the blade. Turn the bandsaw **OFF** and wait for the blade to stop.



3. Clamp the board to the bandsaw table without moving it. Now slide the fence over to the board so it barely touches one end of the board.
4. Loosen the four cap screws on top of the fence.
5. Skew the fence so it is parallel to the edge of the scrap piece. You may need to re-adjust the fence locking mechanisms to gain maximum adjustment.
6. While maintaining the skew, tighten the cap screws.

To shift the table:

1. On a scrap piece of wood, mark a line that is perpendicular to the front edge.
2. Cut halfway through the board on the line by pushing it into the blade.
3. Turn the bandsaw **OFF** and wait for the blade to stop.
4. Loosen the the table mounting bolts, shift the table to compensate for the blade lead, then retighten the bolts.
5. Repeat **Steps 1–4** until the blade cuts straight.

NOTICE

If the table is shifted, the fence will need to be re-aligned, and the blade guides and blade support will need to be re-adjusted.

NOTICE

Lead adjustments will change when new blades are mounted on the saw.

Adjusting Tension Lever

The tension lever has an adjustment screw that allows you to adjust how much tension is released when the lever is used.

Tools Needed:	QTY
Hex Wrench 6mm.....	1
Hex Wrench 5mm.....	1

To adjust the tension lever:

1. DISCONNECT BANDSAW FROM POWER!
2. Loosen the tension lever and remove the blade.
3. Remove the upper wheel by taking out the cap screw at the center of the wheel.
4. Move the tension lever to the tightened position.
5. Turn the adjustment screw shown in **Figure 68** until the gap between the screw and the wheel shaft hinge is $\frac{1}{16}$ "– $\frac{3}{16}$ ".

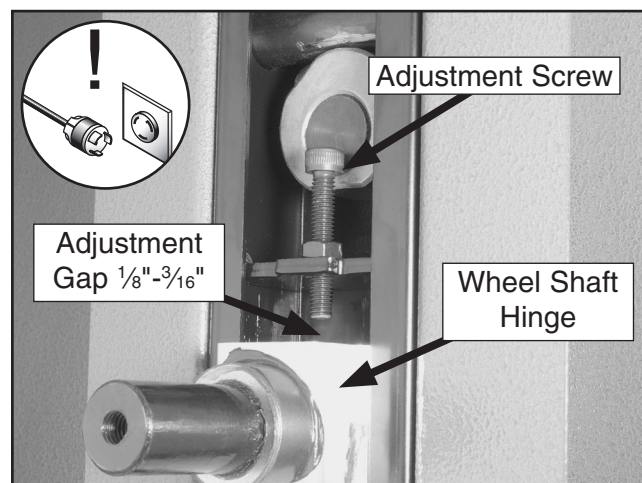

Figure 68. Tension lever adjustment components.

6. Reassemble the removed components and tension and track the blade as normal.



Electrical Component Wiring

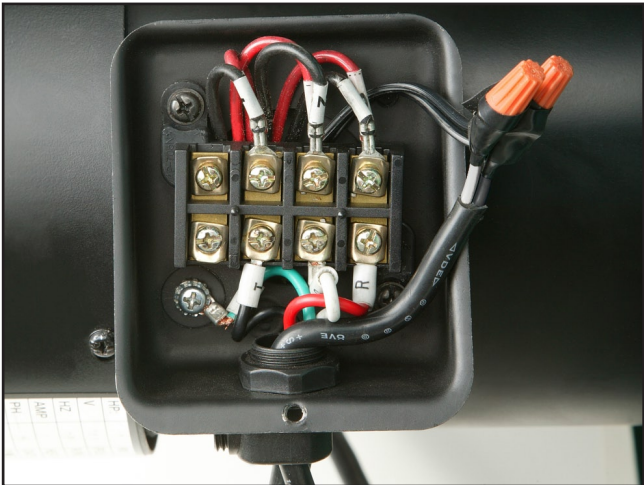

Figure 69. Motor wiring.

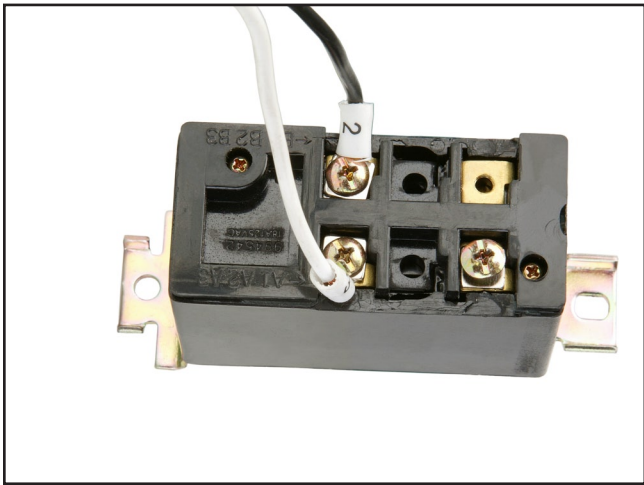

Figure 71. ON/OFF switch.

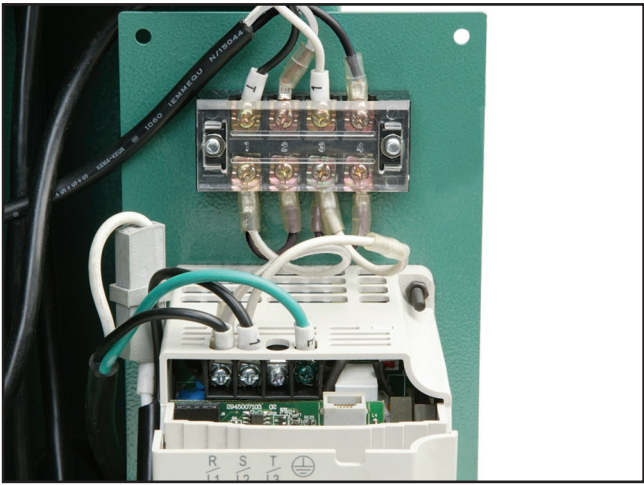

Figure 70. Upper half of power inverter.

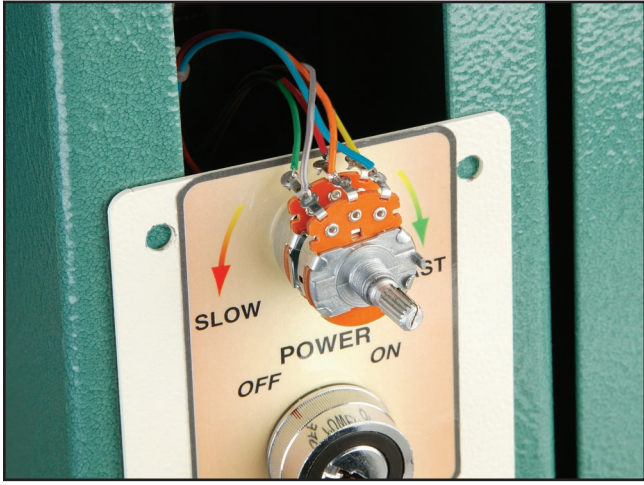

Figure 72. Variable speed dial.

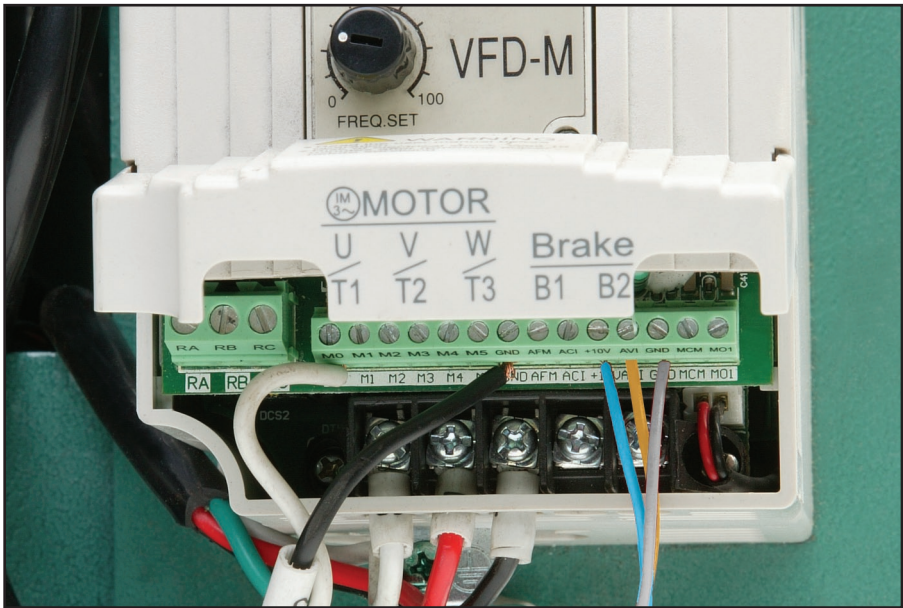
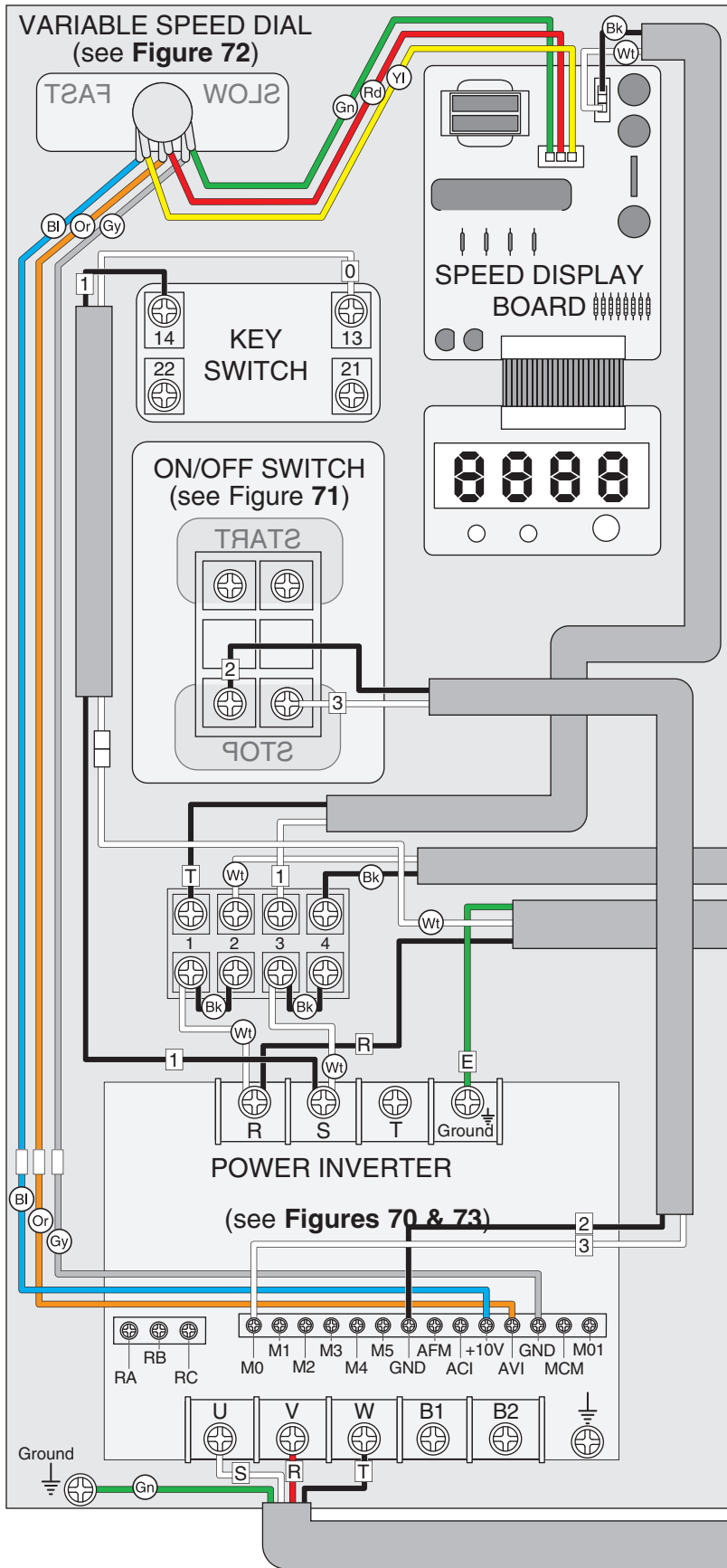

Figure 73. Lower half of power inverter.



Wiring Diagram



WARNING!
SHOCK HAZARD!
Disconnect power
before working on
wiring.

View this wiring diagram in
color at www.grizzly.com.

COLOR KEY

BLACK	Bk	YELLOW	Yl
WHITE	Wt	BLUE	Bl
GREEN	Gn	GRAY	Gy
RED	Rd	ORANGE	Or

NOTICE

The motor wiring shown here is
current at the time of printing;
however, always use the diagram on
the inside of junction box cover
when rewiring your motor.

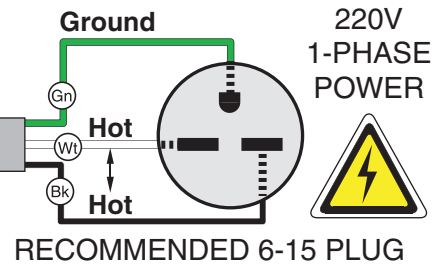

MOTOR 220V 3-PHASE
(see Figure 71)

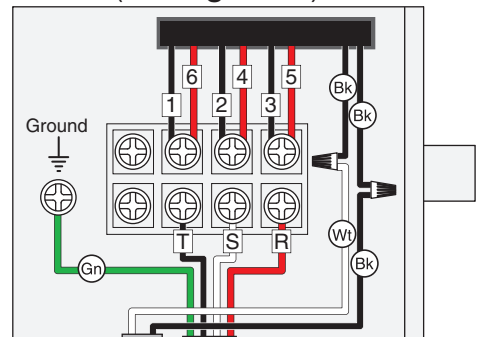

Main Parts

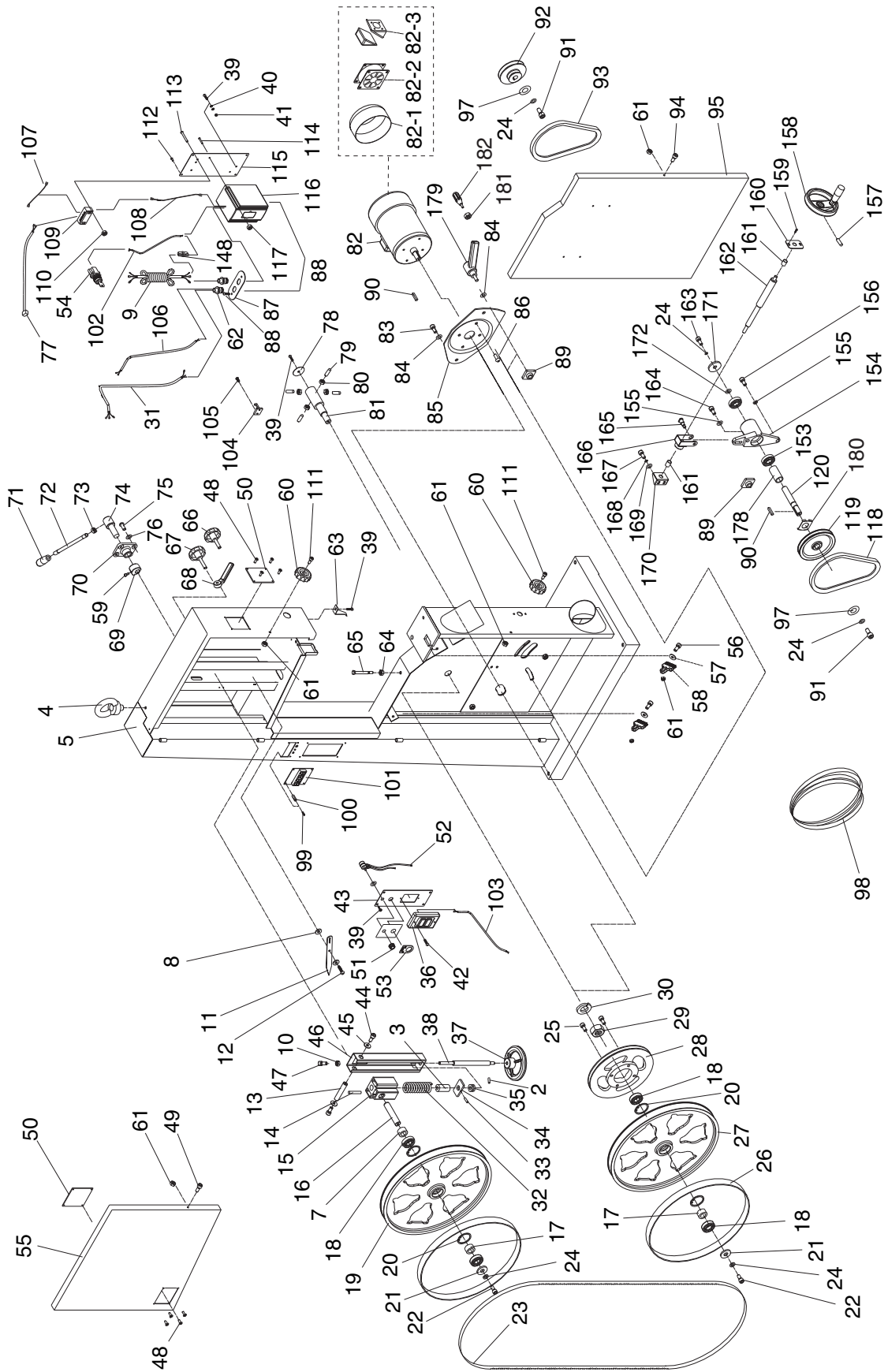

Fence & Blade Guides

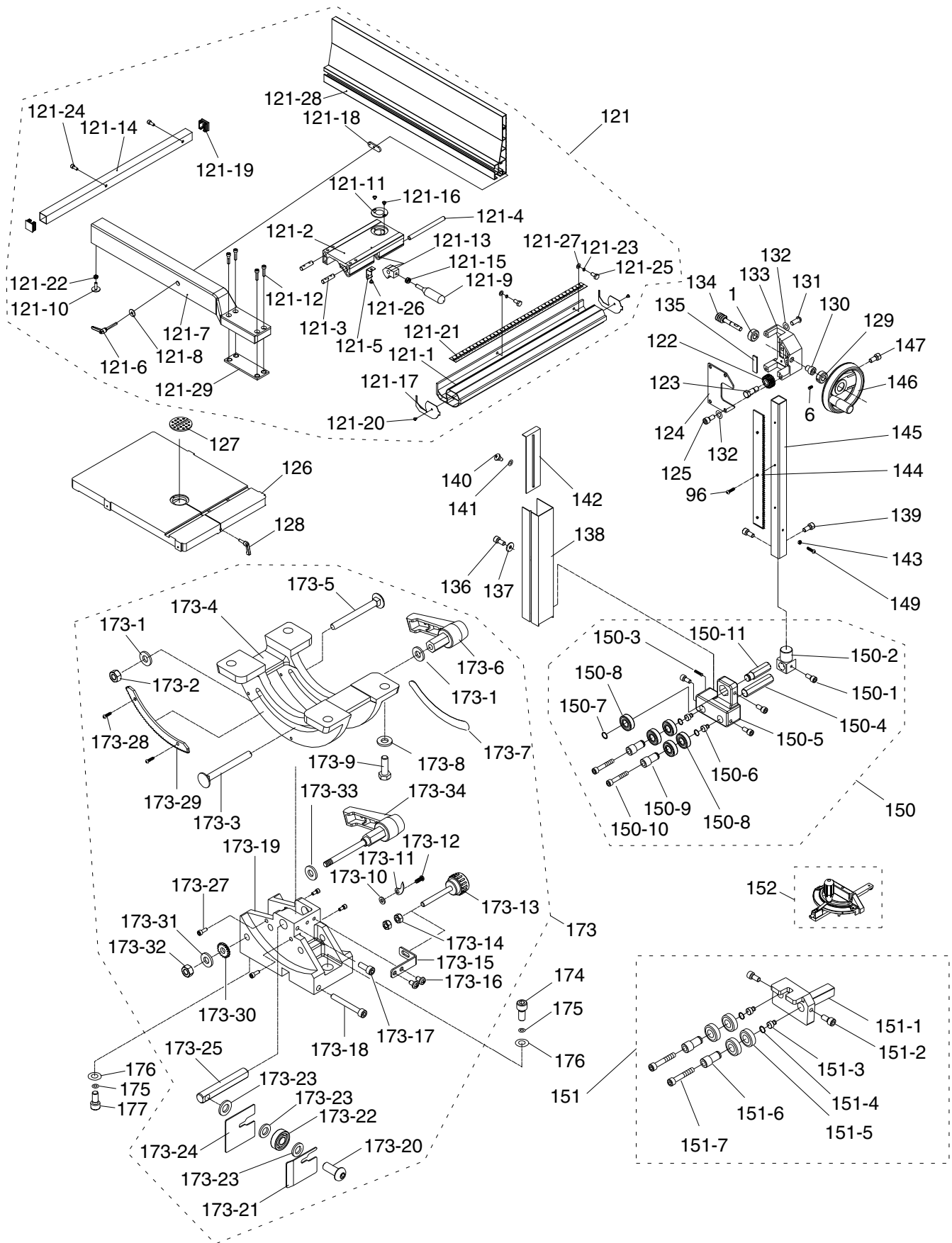

Parts List

REF	PART #	DESCRIPTION
1	P0640X001	BUSHING
2	PSS01M	SET SCREW M6-1 X 10
3	P0640X003	BUSHING
4	P0640X004	LIFTING EYE BOLT
5	P0640X005	MACHINE BODY
6	PSS26M	SET SCREW M5-.8 X 6
7	P0640X007	BUSHING
8	PW05M	FLAT WASHER 4MM
9	P0640X009	POWER CORD 14AWG
10	PN01M	HEX NUT M6-1
11	P0640X011	POINTER
12	P0640X012	STEP SCREW M4-.7 x 6
13	P0640X013	UPPER SHAFT
14	PRP91M	ROLL PIN 5 X 35
15	P0640X015	UPPER WHEEL SHAFT HINGE
16	P0640X016	UPPER WHEEL SHAFT
17	P0640X017	BUSHING
18	P6205	BALL BEARING 6205ZZ
19	P0640X019	UPPER WHEEL 17"
20	PR25M	INT RETAINING RING 47MM
21	PW01M	FLAT WASHER 8MM
22	PSB11M	CAP SCREW M8-1.25 X 16
23	P0640X023	SAW BLADE 131-1/2" X 1/2"
24	PLW04M	LOCK WASHER 8MM
25	PSB14M	CAP SCREW M8-1.25 X 20
26	P0640X026	TIRE
27	P0640X027	LOWER WHEEL 17"
28	P0640X028	IDLE PULLEY
29	PN32	HEX NUT 1"-14
30	PLW09	LOCK WASHER 1"
31	P0640X031	MOTOR CORD 3 WIRE
32	P0640X032	COMPRESSION SPRING
33	PRP02M	ROLL PIN 3 X 16
34	P0640X034	LOCATE BLOCK
35	P51201	THRUST BEARING 51201
36	P0640X036	SWITCH
37	P0640X037	HANDWHEEL
38	P0640X038	ADJUSTING BOLT
39	PFS07M	FLANGE SCREW M5-.8 X 10
40	PTLW02M	EXT TOOTH WASHER 5MM
41	PN06M	HEX NUT M5-.8
42	PFS08M	FLANGE SCREW M5-.8 X 16
43	P0640X043	SWITCH PLATE
44	PSB11M	CAP SCREW M8-1.25 X 16
45	PW01M	FLAT WASHER 8MM
46	P0640X046	UPPER WHEEL SLIDING BRACKET
47	PSB06M	CAP SCREW M6-1 X 25
48	P0640X048	RIVET 3.2 X 10
49	PSB04M	CAP SCREW M6-1 X 10
50	P0640X050	PLASTIC WINDOW
51	P0640X051	VS SWITCH

REF	PART #	DESCRIPTION
52	P0640X052	ADJUSTABLE RESISTOR
53	P0640X053	PLASTIC PIECE
54	P0640X054	KEY SWITCH
55	P0640X055	UPPER WHEEL COVER
56	PB10M	HEX BOLT M6-1 X 25
57	PW03M	FLAT WASHER 6MM
58	P0640X058	BRUSH
59	PSB06M	CAP SCREW M6-1 X 25
60	P0640X060	KNOB
61	PLN03M	LOCK NUT M6-1
62	P0640X062	STRAIN RELIEF 16MM
63	P0640X063	HEIGHT POINTER
64	PN03M	HEX NUT M8-1.25
65	PB45M	HEX BOLT M8-1.25 X 100
66	P0640X066	KNOB SCREW M10-1.5 X 20
67	P0640X067	KNOB SCREW M10-1.5 X 55
68	P0640X068	LOCATE HANDLE M10-1.5
69	P0640X069	CAM
70	P0640X070	LOCATE BLOCK
71	P0640X071	KNOB
72	P0640X072	LEVER ROD
73	PN09M	HEX NUT M12-1.75
74	P0640X074	SHAFT
75	PSBS22M	BUTTON HD CAP SCR M8-1.25 X 20
76	PLW04M	LOCK WASHER 8MM
77	P0640X077	PCB POWER CORD
78	P0640X078	COVER
79	PSS09M	SET SCREW M8-1.25 X 20
80	PN03M	HEX NUT M8-1.25
81	P0640X081	LOWER WHEEL SHAFT
82	P0640X082	MOTOR 1.5 HP 3PH
82-1	P0640X082-1	FAN COVER
82-2	P0640X082-2	FAN
82-3	P0640X082-3	ELECTRICAL BOX COVER
83	PB32M	HEX BOLT M10-1.5 X 25
84	PLW06M	LOCK WASHER 10MM
85	P0640X085	MOTOR BRACKET
86	PSBS22M	BUTTON HD CAP SCR M8-1.25 X 20
87	P0640X087	PLATE
88	PFS07M	FLANGE SCREW M5-.8 X 10
89	P0640X089	LOCATE BLOCK
90	PK15M	KEY 5 X 5 X 35
91	PB81M	HEX BOLT M8-1.25 X 20 (LH)
92	P0640X092	MOTOR PULLEY
93	PVA44	V-BELT A-44 4L440
94	PSB04M	CAP SCREW M6-1 X 10
95	P0640X095	LOWER WHEEL COVER
96	PFH31M	FLAT HD SCR M4-.7 X 8
97	PW01M	FLAT WASHER 8MM
98	P0640X098	METAL SAW BLADE 131-1/2" X 1/2"
99	PS12M	PHLP HD SCR M3-.5 X 6



Parts List

REF	PART #	DESCRIPTION
100	PN07M	HEX NUT M3-.5
101	P0640X101	DISPLAY PCB
102	P0640X102	KEY SWITCH CONNECT LINE 14AWG
103	P0640X103	SWITCH CONNECT LINE 20AWG
104	P0640X104	HOOK BLADE
105	PS38M	PHLP HD SCR M4-.7 X 10
106	P0640X106	MOTOR FAN CONNECT LINE
107	P0640X107	CONNECT LINE
108	P0640X108	CONNECT LINE
109	P0640X109	TERMINAL HOUSE
110	PN04M	HEX NUT M4-.7
111	PSB02M	CAP SCREW M6-1 X 20
112	PHTEK4M	TAP SCREW M4 X 8
113	PS06M	PHLP HD SCR M5-.8 X 20
114	PS40M	PHLP HD SCR M5-.8 X 16
115	P0640X115	CONTROLLER FIXED PLATE
116	P0640X116	AC MOTOR DRIVE 220V 2HP
117	PN06M	HEX NUT M5-.8
118	PVA27	V-BELT A-27 4L270
119	P0640X119	PULLEY
120	P0640X120	SHAFT
121	P0640X121	FENCE SET 590MM
121-1	P0640X121-1	FRONT RAIL 640MM
121-2	P0640X121-2	FENCE BASE
121-3	P0640X121-3	FIXED SHAFT
121-4	P0640X121-4	SHAFT
121-5	P0640X121-5	SPRING PIECE
121-6	P0640X121-6	LOCK HANDLE M8 X 44
121-7	P0640X121-7	FENCE 590MM
121-8	PW01M	FLAT WASHER 8MM
121-9	P0640X121-9	FENCE HANDLE M8-1.25 X 22
121-10	P0640X121-10	RAIL PAD
121-11	P0640X121-11	CONVEX
121-12	PSB06M	CAP SCREW M6-1 X 25
121-13	P0640X121-13	FIXED LUMP
121-14	P0640X121-14	REAR RAIL 640MM
121-15	PN03M	HEX NUT M8-1.25
121-16	PFS04M	FLANGE SCREW M4-.7 X 6
121-17	P0640X121-17	GUARD PIECE
121-18	P0640X121-18	T-SLOT NUT
121-19	P0640X121-19	PLUG
121-20	PHTEK3M	TAP SCREW M3.5 X 8
121-21	P0640X121-21	SCALE
121-22	PN01M	HEX NUT M6-1
121-23	PLW03M	LOCK WASHER 6MM
121-24	PSB114M	CAP SCREW M6-1 X 22
121-25	PB08M	HEX BOLT M6-1 X 20
121-26	PFB13M	FLANGE BOLT M4-.7 X 8
121-27	PW03M	FLAT WASHER 6MM
121-28	P0640X121-28	RESAW FENCE (AL) 590MM
121-29	P0640X121-29	SPACER PLATE
122	P0640X122	GEAR

REF	PART #	DESCRIPTION
123	P0640X123	FIXED BOLT
124	P0640X124	COVER
125	PSB11M	CAP SCREW M8-1.25 X 16
126	P0640X126	TABLE 17" X 24"
127	P0640X127	TABLE INSERT
128	P0640X128	TABLE PIN
129	P0640X129	LOCATE BUSHING
130	P0640X130	BUSHING
131	PSBS22M	BUTTON HD CAP SCR M8-1.25 X 20
132	PLW04M	LOCK WASHER 8MM
133	P0640X133	GUIDE BRACKET
134	P0640X134	WORM CYLINDER
135	P0640X135	FIXED PLATE
136	PSB50M	CAP SCREW M5-.8 X 10
137	PW02M	FLAT WASHER 5MM
138	P0640X138	PROTECT COVER
139	PSB01M	CAP SCREW M6-1 X 16
140	P0640X140	STEP SCREW
141	P0640X141	FIBER WASHER
142	P0640X142	SLIDING PLATE
143	PN04M	HEX NUT M4-.7
144	P0640X144	RACK
145	P0640X145	UPPER GUIDE HOSE
146	P0640X146	HANDWHEEL
147	PSB02M	CAP SCREW M6-1 X 20
148	P0640X148	CORD CONNETOR 224-201
149	PS38M	PHLP HD SCR M4-.7 X 10
150	P0640X150	UPPER GUIDE ASSEMBLY
150-1	PSB01M	CAP SCREW M6-1 X 16
150-2	P0640X150-2	UPPER GUIDE SUPPORT BLOCK
150-3	PSS01M	SET SCREW M6-1 X 10
150-4	P0640X150-4	ADJUST BAR
150-5	P0640X150-5	UPPER BLADE GUIDE SUPPORT
150-6	P0640X150-6	ECCENTRIC SHAFT
150-7	PR05M	EXT RETAINING RING 15MM
150-8	P6202	BALL BEARING 6202ZZ
150-9	P0640X150-9	HANDLE BUSHING
150-10	PSB48M	CAP SCREW M6-1 X 35
150-11	P0640X150-11	UPPER SPACING SLEEVE
151	P0640X151	LOWER GUIDE ASSEMBLY
151-1	P0640X151-1	LOWER BLADE GUIDE SUPPORT
151-2	PSB01M	CAP SCREW M6-1 X 16
151-3	P0640X151-3	ECCENTRIC SHAFT
151-4	PR05M	EXT RETAINING RING 15MM
151-5	P6202	BALL BEARING 6202ZZ
151-6	P0640X151-6	HANDLE BUSHING
151-7	PSB48M	CAP SCREW M6-1 X 35
152	P0640X152	MITER GAUGE ASSEMBLY
153	P6204LLU	BALL BEARING 6204LLU
154	P0640X154	BEARING STAND
155	PLW06M	LOCK WASHER 10MM



Parts List

REF	PART #	DESCRIPTION
156	PB32M	HEX BOLT M10-1.5 X 25
157	PSS02M	SET SCREW M6-1 X 6
158	P0640X158	HANDWHEEL
159	PFS11M	FLANGE SCREW M6-1 X 10
160	P0640X160	FIXED PLATE
161	P0640X161	SELF-LUBRICATED BUSHING
162	P0640X162	ADJUSTING BOLT
163	PSBS22M	BUTTON HD CAP SCR M8-1.25 X 20
164	PSB84M	CAP SCREW M10-1.5 X 35
165	P0640X165	SHAFT BOLT
166	P0640X166	ADJUSTING STAND
167	PSB01M	CAP SCREW M6-1 X 16
168	PLW03M	LOCK WASHER 6MM
169	PW03M	FLAT WASHER 6MM
170	P0640X170	FIXED STAND
171	P0640X171	SPACER
172	PW01M	FLAT WASHER 8MM
173	P0640X173	CAST IRON TRUNNION ASSEMBLY
173-1	PW01M	FLAT WASHER 8MM
173-2	PLN04M	LOCK NUT M8-1.25
173-3	PCB10M	CARRIAGE BOLT M8-1.25 X 85
173-4	P0640X173-4	UPPER TRUNNION
173-5	PCB23M	CARRIAGE BOLT M8-1.25 X 80
173-6	P0640X173-6	LOCK HANDLE M8-1.25
173-7	P0640X173-7	ANGLE LABEL
173-8	PW01M	FLAT WASHER 8MM
173-9	PB07M	HEX BOLT M8-1.25 X 25
173-10	PW05M	FLAT WASHER 4MM
173-11	P0640X173-11	POINTER
173-12	PS17M	PHLP HD SCR M4-.7 X 6

REF	PART #	DESCRIPTION
173-13	P0640X173-13	ADJUST BOLT M6-1
173-14	PN01M	HEX NUT M6-1
173-15	P0640X173-15	ADJUST PLATE
173-16	PFH01M	FLAT HD SCR M5-.8 X 15
173-17	PSB01M	CAP SCREW M6-1 X 16
173-18	PSB37M	CAP SCREW M6-1 X 50
173-19	P0640X173-19	TRUNNION SUPPORT BRACKET
173-20	PSBS19M	BUTTON HD CAP SCR M10-1.5 X 30
173-21	P0640X173-21	RIGHT COVER
173-22	P6000	BALL BEARING 6000ZZ
173-23	PW04M	FLAT WASHER 10MM
173-24	P0640X173-24	LEFT COVER
173-25	P0640X173-25	ADJUST BLOCK
173-27	PSB97M	CAP SCREW M5-.8 X 6
173-28	PS17M	PHLP HD SCR M4-.7 X 6
173-29	P0640X173-29	TRUNNION RACK
173-30	P0640X173-30	TRUNNION PINION
173-31	PW01M	FLAT WASHER 8MM
173-32	PLN04M	LOCK NUT M8-1.25
173-33	PW06M	FLAT WASHER 12MM
173-34	P0640X173-34	TABLE TILT HANDLE
174	PSB72M	CAP SCREW M10-1.5 X 30
175	PLW06M	LOCK WASHER 10MM
176	PW04M	FLAT WASHER 10MM
177	PSB84M	CAP SCREW M10-1.5 X 35
178	P0640X178	BUSHING
179	P0640X179	ADJUSTABLE LOCK LEVER
180	P0640X180	BEARING STAND PLATE
181	PN03M	HEX NUT M8-1.25
182	P0640X182	HANDLE



Labels

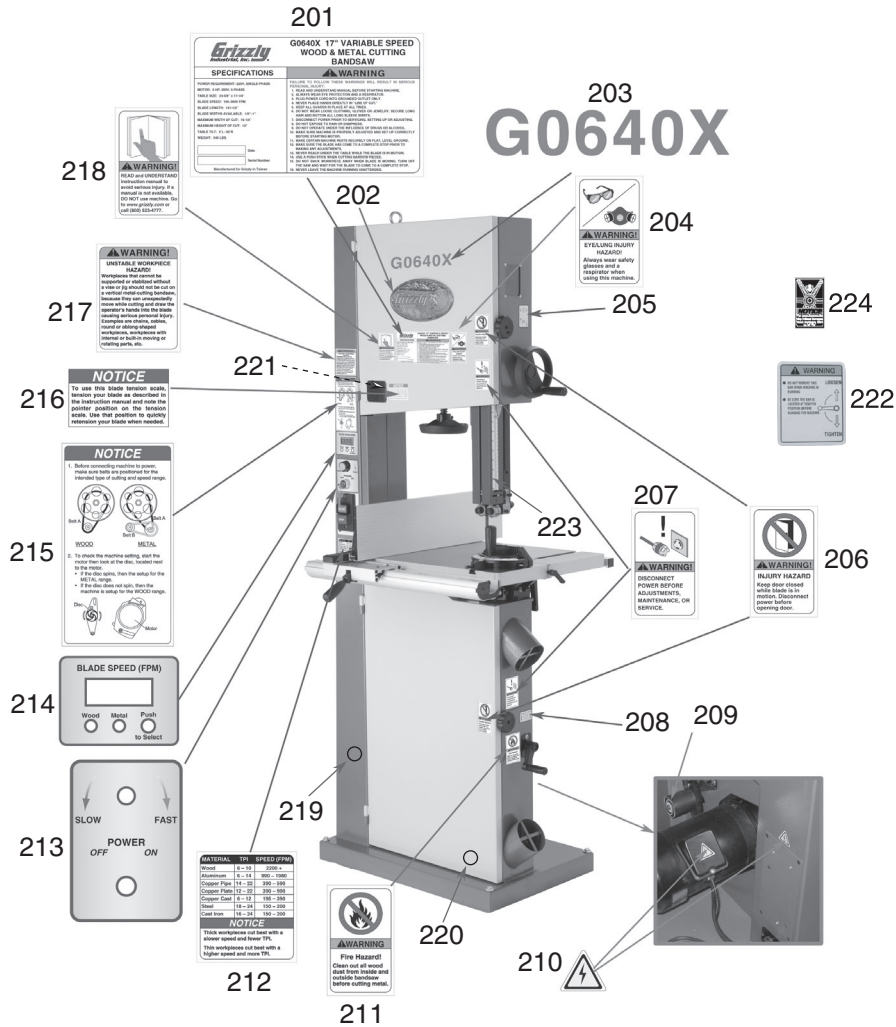

REF	PART #	DESCRIPTION
201	P0640X201	MACHINE ID LABEL
202	G8588	GRIZZLY NAMEPLATE
203	P0640X203	G0640X MODEL # LABEL
204	PLABEL-43	GLASSES RESPIRATOR LABEL
205	P0640X205	GUIDE POST ADJUSTMENT LABEL
206	PLABEL-30	DOOR CLOSED LABEL
207	PLABEL-18	DISCONNECT POWER-BANDSAW
208	P0640X208	HAND CRANK DIRECTION LABEL
209	P0640X209	SPIRAL INDICATOR LABEL
210	PLABEL-14	ELECTRICITY LABEL
211	P0640X211	FIRE HAZARD LABEL
212	P0640X212	CUTTING SPEEDS LABEL

REF	PART #	DESCRIPTION
213	P0640X213	CONTROLS LABEL
214	P0640X214	SPEED DISPLAY LABEL
215	P0640X215	BELT CHANGE LABEL
216	P0640X216	BLADE TENSION LABEL
217	P0640X217	UNSTABLE WORKPIECE LABEL
218	PLABEL-12A	READ MANUAL LABEL
219	PPAINT-1	"GRIZZLY GREEN" PAINT
220	PPAINT-11	"PUTTY" PAINT
221	P0640X221	BLADE TENSION SCALE LABEL
222	P0640X222	BLADE TENSION LEVER LABEL
223	P0640X223	GUIDE POST SCALE
224	P0640X224	TENSION ADJUSTMENT LABEL

⚠ WARNING

Safety labels warn about machine hazards and ways to prevent injury. The owner of this machine **MUST** maintain the original location and readability of the labels on the machine. If any label is removed or becomes unreadable, **REPLACE** that label before using the machine again. Contact Grizzly at (800) 523-4777 or www.grizzly.com to order new labels.





WARRANTY CARD

Name _____
 Street _____
 City _____ State _____ Zip _____
 Phone # _____ Email _____ Invoice # _____
 Model # _____ Order # _____ Serial # _____

The following information is given on a voluntary basis. It will be used for marketing purposes to help us develop better products and services. **Of course, all information is strictly confidential.**

1. How did you learn about us?

Advertisement Friend Catalog
 Card Deck Website Other:

2. Which of the following magazines do you subscribe to?

<input type="checkbox"/> Cabinet Maker	<input type="checkbox"/> Popular Mechanics	<input type="checkbox"/> Today's Homeowner
<input type="checkbox"/> Family Handyman	<input type="checkbox"/> Popular Science	<input type="checkbox"/> Wood
<input type="checkbox"/> Hand Loader	<input type="checkbox"/> Popular Woodworking	<input type="checkbox"/> Wooden Boat
<input type="checkbox"/> Handy	<input type="checkbox"/> Practical Homeowner	<input type="checkbox"/> Woodshop News
<input type="checkbox"/> Home Shop Machinist	<input type="checkbox"/> Precision Shooter	<input type="checkbox"/> Woodsmith
<input type="checkbox"/> Journal of Light Cont.	<input type="checkbox"/> Projects in Metal	<input type="checkbox"/> Woodwork
<input type="checkbox"/> Live Steam	<input type="checkbox"/> RC Modeler	<input type="checkbox"/> Woodworker West
<input type="checkbox"/> Model Airplane News	<input type="checkbox"/> Rifle	<input type="checkbox"/> Woodworker's Journal
<input type="checkbox"/> Modeltec	<input type="checkbox"/> Shop Notes	<input type="checkbox"/> Other:
<input type="checkbox"/> Old House Journal	<input type="checkbox"/> Shotgun News	

3. What is your annual household income?

\$20,000-\$29,000 \$30,000-\$39,000 \$40,000-\$49,000
 \$50,000-\$59,000 \$60,000-\$69,000 \$70,000+

4. What is your age group?

20-29 30-39 40-49
 50-59 60-69 70+

5. How long have you been a woodworker/metalworker?

0-2 Years 2-8 Years 8-20 Years 20+ Years

6. How many of your machines or tools are Grizzly?

0-2 3-5 6-9 10+

7. Do you think your machine represents a good value? Yes No

8. Would you recommend Grizzly Industrial to a friend? Yes No

9. Would you allow us to use your name as a reference for Grizzly customers in your area?
Note: We never use names more than 3 times. Yes No

10. Comments: _____

CUT ALONG DOTTED LINE

FOLD ALONG DOTTED LINE



Place Stamp Here



GRIZZLY INDUSTRIAL, INC.
P.O. BOX 2069
BELLINGHAM, WA 98227-2069



FOLD ALONG DOTTED LINE

Send a Grizzly Catalog to a friend:

Name _____
Street _____
City _____ State _____ Zip _____

TAPE ALONG EDGES--PLEASE DO NOT STAPLE

WARRANTY AND RETURNS

Grizzly Industrial, Inc. warrants every product it sells for a period of **1 year** to the original purchaser from the date of purchase. This warranty does not apply to defects due directly or indirectly to misuse, abuse, negligence, accidents, repairs or alterations or lack of maintenance. This is Grizzly's sole written warranty and any and all warranties that may be implied by law, including any merchantability or fitness, for any particular purpose, are hereby limited to the duration of this written warranty. We do not warrant or represent that the merchandise complies with the provisions of any law or acts unless the manufacturer so warrants. In no event shall Grizzly's liability under this warranty exceed the purchase price paid for the product and any legal actions brought against Grizzly shall be tried in the State of Washington, County of Whatcom.

We shall in no event be liable for death, injuries to persons or property or for incidental, contingent, special, or consequential damages arising from the use of our products.

To take advantage of this warranty, contact us by mail or phone and give us all the details. We will then issue you a "Return Number," which must be clearly posted on the outside as well as the inside of the carton. We will not accept any item back without this number. Proof of purchase must accompany the merchandise.

The manufacturers reserve the right to change specifications at any time because they constantly strive to achieve better quality equipment. We make every effort to ensure that our products meet high quality and durability standards and we hope you never need to use this warranty.

Please feel free to write or call us if you have any questions about the machine or the manual.

Thank you again for your business and continued support. We hope to serve you again soon.

grizzly.com

TOOL WEBSITE

Buy Direct and Save with Grizzly® – Trusted, Proven and a Great Value!

*Visit Our Website Today And Discover
Why Grizzly® Is The Industry Leader!*

- SECURE ORDERING
- ORDERS SHIPPED WITHIN 24 HOURS
- E-MAIL RESPONSE WITHIN ONE HOUR

-OR-

Call Today For A **FREE**
Full Color Catalog

1-800-523-4777

